



ALL-ELECTRIC MOFFETT E-SERIES NX **ADDING GREEN TO FUTURE LOGISTICS**



PRODUCT RANGE BROCHURE

THREE SIZES OF GREEN



The MOFFETT eSeries NX has been developed based on the world's first all-electric truck mounted forklift, a revolutionary turn in forklift logistics. Available in three different sizes, this next generation all-electric eSeries makes a green choice an easy one. All MOFFETT eSeries NX feature all wheel drive, 4-way steering, high-tech dash display, real-time operational insight and multiple charging options.



Since the MOFFETT eSeries NX generates no emissions, very little noise and no vibration, it is ideal for moving goods from outside to inside, quiet night deliveries in residential areas and work in Low Emission Zones. It's powerful, silent and environmentally responsible. Choose the one that suits your needs.





E5 NX



E8 NX

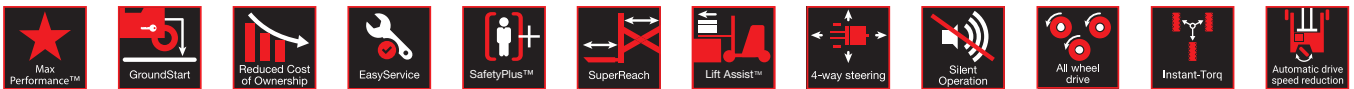

BENEFITS OF THE MOFFETT E-SERIES NX

Discover the all-electric MOFFETT eSeries NX truck mounted forklifts.

- **All-electric drive:** All-electric permanent magnet wheel motors give you perfect control over each wheel. An all-electric motor creates less waste energy thus giving you vastly improved efficiency and longer battery life.
- **100% emission-free:** The MOFFETT eSeries NX is equipped with the latest lithium-ion battery technology, which means it does not generate any emissions. Perfect for working indoors without polluting the environment.
- **4-way steering:** A MOFFETT eSeries can drive forward, backward, left and right (multidirectional), making it possible for you to operate within narrow access area and transport long loads with ease.
- **Near silent operation:** Being all-electric, the MOFFETT eSeries NX is practically silent, which makes it ideal for urban and night-time deliveries.
- **HMI Display:** A new generation dash display gives you all information on how the machine is operating. It can also show various behind the scenes menus for the purpose of maintenance.
- **All-wheel drive:** To give you even more flexibility, the MOFFETT eSeries NX is all wheel drive via permanent magnet high torque wheel motors and secures maximum traction on all surfaces.
- **Instant-Torq:** High torque, all-electric permanent magnet wheel motors give you instant power and perfect control over each wheel.
- **Automatic drive speed reduction:** As the MOFFETT steering angle increases, ground speed automatically reduces, making cornering safer.
- **Equipped with Hiab HiConnect:** Thanks to HiConnect (telematics), the forklift's location and vital parameters can be monitored online at all times.
- **Easy charging:** The MOFFETT eSeries NX can be charged from a conventional wall socket, and also via an on-board charger when the delivery truck is traveling between jobs, giving maximum flexibility.

INCREASE YOUR REVENUES, REDUCE YOUR OPERATING COSTS

A MOFFETT truck mounted forklift is the ideal productivity tool for delivering more in your business – and for gaining more. More precision, more versatility, more profitability, more competitive edge.

Gain even more business with MOFFETT eSeries NX

The all-electric, emission free MOFFETT eSeries NX has the ability to go where no other truck mounted forklift has gone before, giving increased flexibility and utilisation.

It is ideal for:

- Moving goods from outside to inside in warehouses or distribution centres. Thanks to a great lift capacity, a powerful all-wheel drive traction system and a tight turning circle, you will be able to access the most confined areas.
- Urban deliveries in areas with restricted access, where low noise is paramount. No engine noise and zero emissions mean you can travel right to the point of delivery.
- Night-time delivery operations in residential areas where this silent operator will help you move without disturbing the environment.



Quiet Mark is a global certification programme that identifies the quietest products in multiple categories.



IFOY AWARD (International Intralogistics and Forklift Truck of the Year) is the "Oscar" of intralogistics. It recognises the year's best intralogistics products and solutions.

MOFFETT eSeries NX offers great savings

Running costs for the MOFFETT eSeries NX are only approximately 20% of a diesel equivalent. Also, the machine has fewer moving parts that need to be maintained or replaced. This greatly reduces both service time and parts cost. Not to mention you eliminate any CO₂ and other emissions, which makes the eSeries a truly sustainable choice.

Diesel vs electric – total cost of ownership breakdown*

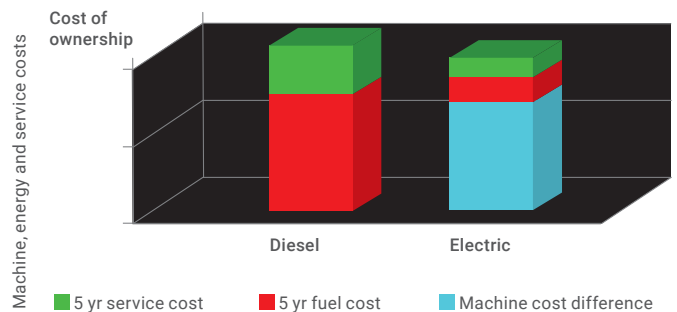

Total cost of ownership breakdown vs years

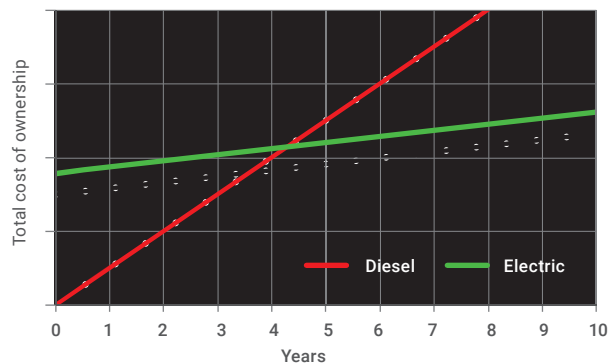

* Data based on estimated machine cost difference, energy figures from Eurostat, service figures based on main TMFL EU market averages, usage 300 hrs annually



Work smarter, charge faster between jobs.

When fully charged, the MOFFETT eSeries NX can unload up to 60 pallets, each weighing 2.5 tons, 25 metres from the truck, a task that takes approximately 2 hours. Standard charge from a wall socket takes 6

hours, but a fast 2-hour charge from a 32A socket is also possible (optional). You can also easily charge your MOFFETT eSeries onboard using truck charging when traveling between jobs.

Battery capacity – pallets handled vs distance

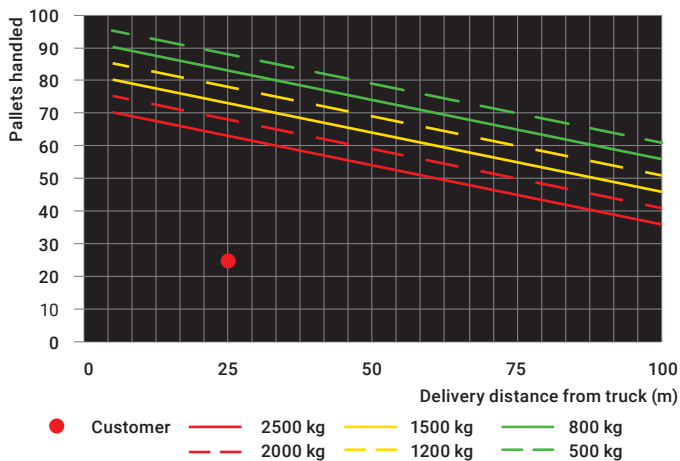

Battery charge time vs SOC

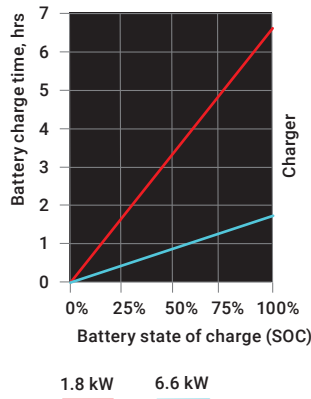

Battery capacity – delivery cycle – truck charging

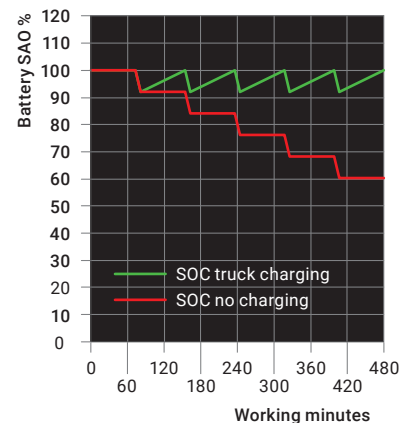

Note: 6.6 kW Charger requires a 32 A socket Note: based on 2500 kg @25 m delivery

All-electric means ultra efficient

Each wheel is driven by a permanent magnet electric motor with integrated software. By putting the motor in the wheel waste energy is greatly reduced thus giving you maximum efficiency.

Eliminating hydraulic wheel motors also means less noise, fewer parts, lower maintenance, more uptime and thus increased productivity.

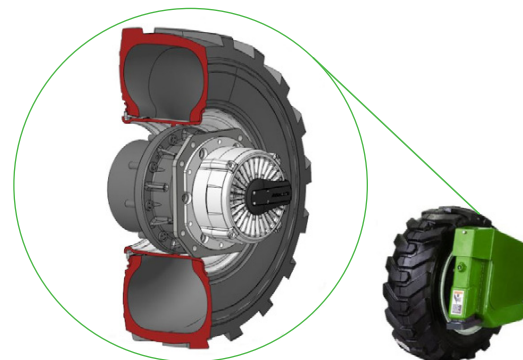

Loud		Medium		Quiet	
Jumbo jet		Diesel-driven truck mounted forklift		eSeries NX	
< 120 dBa		84 – 120 dBa		< 84 dBa	

Since the decibel scale is logarithmic, the percentual sound reduction is much bigger than the nominal dB reduction.

HIAB HICONNECT FOR MOFFETT

The MOFFETT eSeries NX features HiConnect, which offers you real-time overview of more than 100 machine parameters. You can see some of them on the dash display and others on the HiConnect portal. The parameters range from battery capacity to delivery route and time, driver safety and maintenance notifications.

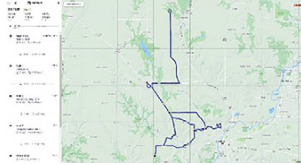

SUPERIOR SAFETY

With MOFFETT eSeries, we have taken all measures to ensure safety. The bonnet is designed for maximum visibility and interlocking seat belt prevents driving if not connected. LED lights/beacon add to the safety and convenience of the driver. In addition, with GroundStart™ as standard dismounting the MOFFETT eSeries is now even easier no matter the location.

The structures surrounding the battery are designed to ensure full safety even in the case of an accident. The construction of the chassis has been verified in tests at MIRA crash laboratory. Our testing ensures full protection for the driver, the surroundings and the environment.



A WHOLE RANGE OF MACHINES

The MOFFETT eSeries truck mounted forklift is available in several versions and more will be added over time. This means that whatever your load handling ambitions, there will always be a MOFFETT eSeries model to help you achieve them.



MOFFETT E4 NX



MOFFETT E5 NX



MOFFETT E8 NX

MOFFETT eSeries

	MOFFETT E4	MOFFETT E5	MOFFETT E8
Battery type	Manganese Laminate Li-on (LMNC)		
Lift capacity (kg)	2000 – 2500	2000 – 2500	2500 – 3500
Lift height (mm)	2200 – 3000	3000	3040
Overhang (mm)	1205 – 1255	1200 – 1250	1475
Ground clearance (mm)	200 – 260	180	220 – 245
Drive wheels	1/3	3	3
4-way steering	✓	✓	✓

*The above specifications can be changed by the manufacturer without prior notice.
* The values vary depending on machine specification.*

DELIVER AS PROMISED WITH HIAB SERVICES

When you invest in Hiab equipment, you invest in quality performance to safely and efficiently fulfill your commitments to your customers – every single day.

With Hiab Services, we are here for you throughout your equipment lifecycle, giving the uptime and reliability you need to deliver as promised. From the moment of installation, we can ensure that your Hiab equipment keeps its original performance – delivering always to your expectations.

With the latest tools, connectivity and a wide network of experts, we support you whenever and wherever you need us. So you can sleep well at night – every single night.



Hiab Original Parts

Hiab Original Parts ensure that your Hiab product stays a Hiab product. Keep the same functionality and quality you invested in from the start – essential for optimal performance, maximum safety and avoiding costly downtime.



Powering on with first-rate service coverage

Reliable and indispensable transport load handling saves time and resources. Protect your investment with the best coverage possible with a tailor-made Hiab service and maintenance contract.

Your truck mounted forklift investment needs to be able to handle loads with ease and precision. Take the worry out of any foreseen equipment issues with a preventative service plan that will keep your MOFFETT operating as good-as-new.

ProCare™ for MOFFETT will take care of all of your service needs, without taking time and resources away from your core business

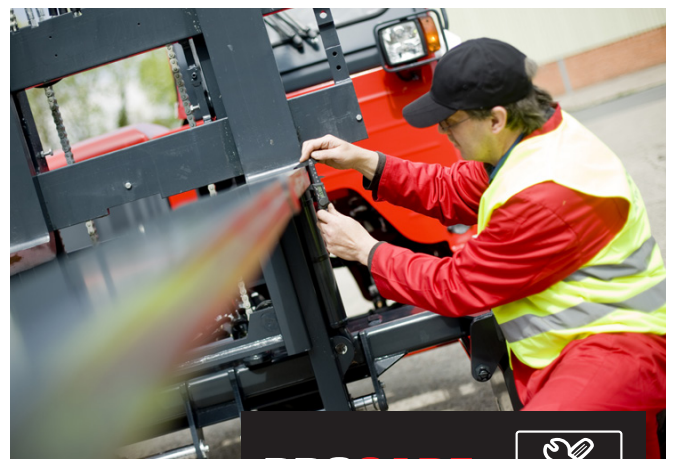

PRO CARE™





Global presence
and local service bring
our products and solutions
closer to our customer

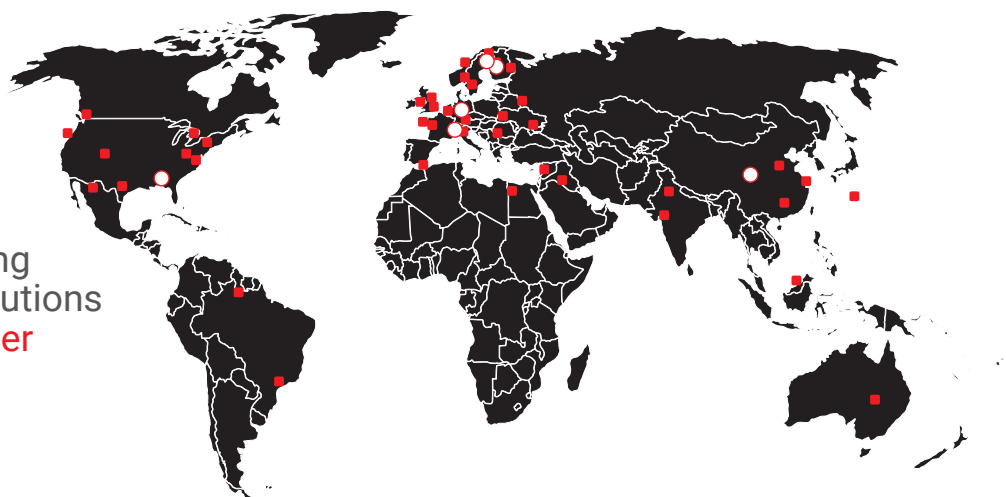

BUILT TO PERFORM

Hiab is the world's leading provider of on-road load handling equipment, intelligent services, smart and connected solutions. Hiab's class-leading load handling equipment includes HIAB, EFFER and ARGOS loader cranes, LOGLIFT and JONSERED forestry and recycling cranes, MOFFETT and PRINCETON truck mounted forklifts, MULTILIFT skiploaders and hooklifts, and tail lifts under the ZEPRO, DEL, and WALTCO brands. As the industry pioneer and with a proud 75 year history, Hiab is committed to be the preferred partner and solution provider to its customers and shape the future of intelligent load handling.

hiab.com

Hiab is part of Cargotec Corporation.

cargotec.com

