



iQ.708 HIPRO

THE BALANCED CRANE DESIGNED FOR YOUR BALANCE SHEET

The HIAB iQ.708 HIPRO is designed from the very beginning to increase the payload available to customers on their truck installations, a critical item for the activities which mainly rely in this segment of use in order to transport the most material and objects as possible.



POSITIVELY IMPACT YOUR BALANCE SHEET

- Lightweight crane structure leaves more payload for carrying materials.
- Reduce fuel consumption with fewer transport travels.

POSITIVELY IMPACT YOUR EFFICIENCY

- Standard features make operating the crane on a daily basis easier for all types of operators.
- The Dynamic Load Charts helps save time by checking the simulated stability from the comfort of the remote control.

POSITIVELY IMPACT YOUR CHOICES

- Compact frame dimensions fitting more truck installation proposals.
- Get more jobs done with the choice of up to an 8 extension with JIB 6 extension combination, or 9 extension for long reach.



STANDARD FEATURES FOR MAXIMUM LIFTING

LAYOUTS AND OPTIONS for a wide variety of uses

Choose among several options or architecture layouts to best fit your needs.

- Variants with 6, 7, 8 or 9 extensions.
- JIB combination with 7 or 8 extension crane versions
- JIB 155Q-6 (V12-Power profile shape).
- Raised hook extension.
- 2t and 3,5t Hoist



VARIABLE STABILITY LOGIC PLUS (VSL+) with Dynamic Load Chart (DLC)

VSL+ is a safety system that maximises capacity by actively calculating the stability according to the position of the stabiliser legs and the total weight of the truck. By accounting for the true load, it can provide significantly more lifting capacity when it really matters.

The innovative V12-Power boom shape, for both the crane and JIB, is the result of Hiab's engineering department to develop products that are suited for the application they are going to be used for. The uncompromised design delivers the highest level of heavy lifting performance in a crane of this category.

- 'Up and over' of 26m.
- Maximum vertical reach of 40m.

V12 POWER



Optional features

Reduce operator stress with SDC synchronized distance control

This function removes the stress of having to maneuver multiple functions from the remote control at the same time, it automatically keeps the hoist position when moving the crane boom and JIB.

- Reduces operator stress.
- Avoids risking damages to equipment, people and objects.
- Assistance for all level skilled operators.

The highest level of safety with Confirmed View

With the introduction of the next generation remote control CD4, the crane detects on which side the operator is compared to the crane, and it enables him to activate the stabilizers in full safety and with the complete view of their opening.

Increase job opportunities with MEWP

Increase the variety of jobs your company can do by choosing the man basket pre-setting, making it easy to add this useful item when needed.

Other optional features:

- SAF (Semi Automatic Folding)

DRIVING THE CRANE OF THE FUTURE

SPACEevo is an open and modular platform, that allows to add and create new functionalities over time, assuring the HIAB iQ.708 HIPRO a long lasting operating time over the years and a higher residual value. The dual-core processor, the sensors, the actuators and the new harness design assure working in all conditions, giving power to the crane it needs, while increasing its reliability and durability for completing the most difficult jobs.



CD4 (CombiDrive4) The remote of the future

DISPLAY: Excellent control over the crane movements; data and alerts clearly readable with the new three big color displays.

MADE FOR THE OPERATORS:

- Powerful working area light.
- Battery with personalized operator crane settings.
- Haptic feedback for alerts and crane reactions.

SAFETY: The new remote communicates with the crane the position of the driver (with the optional Confirmed View), for opening the stabilisers only when in full sight of their view.

The high quality components, the latest generation hydraulics, sensors, cables and the Olsbergs V200 valve all contribute in harmony for a durable and reliable crane for an exceptional low cost of ownership over the years.

Save money with variable pump

With the standard variable pump, reduce the need for fuel, using it only when lifting operations really occur. Less fuel, more savings and a positive impact on the environment.

HiConnect ready

Digitalisation and connectivity give you an added edge over competition, by handling and managing your crane, or fleet of cranes. Making decisions based on data driven information allows you to manage the daily workload and plan pre-emptively your maintenance schedules minimising downtimes.



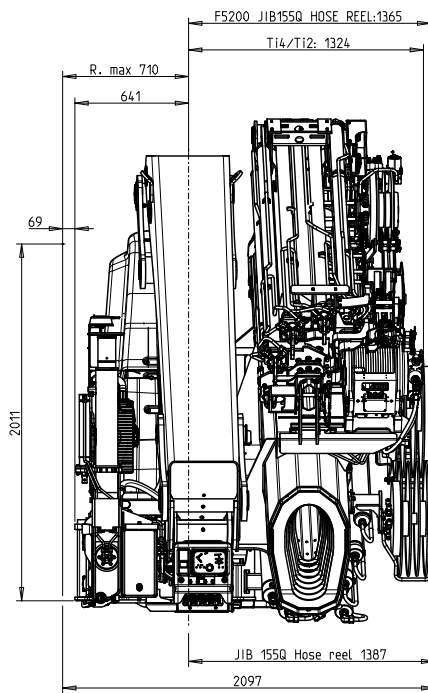
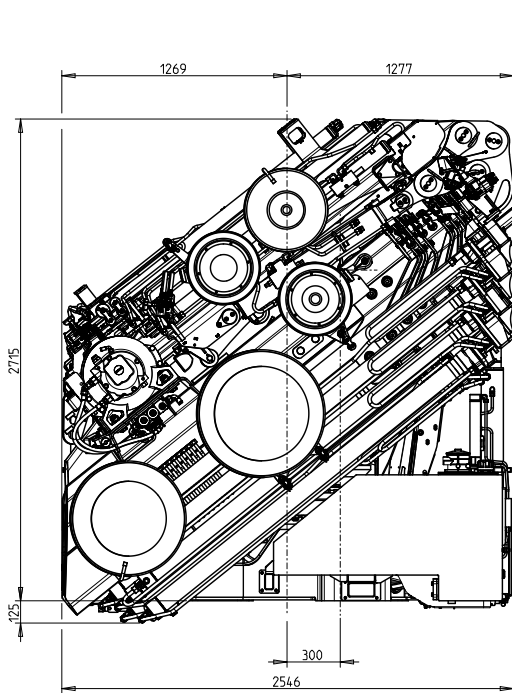
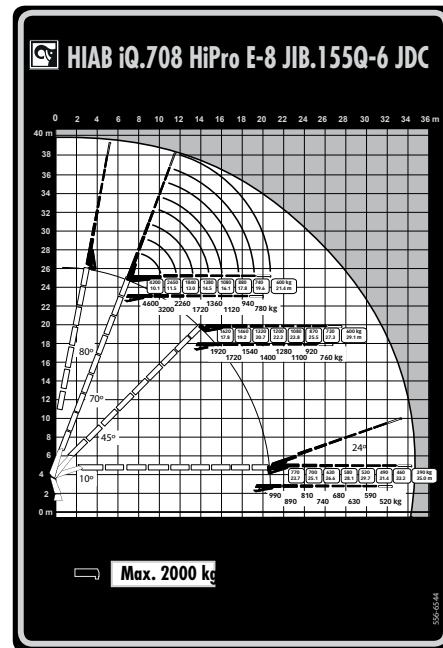
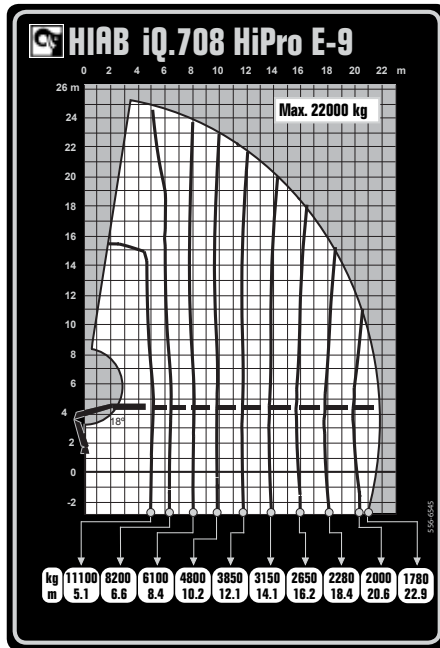
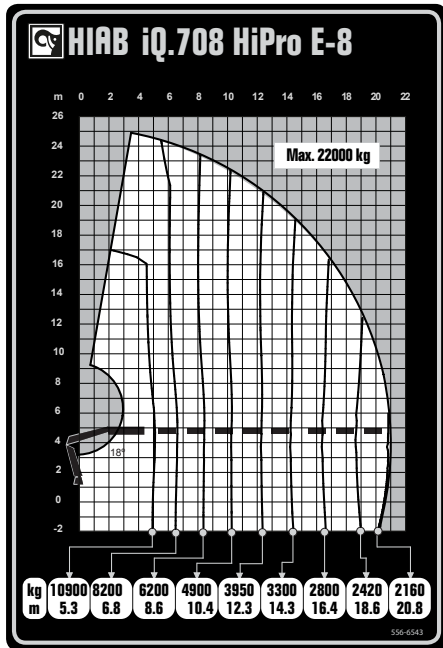

TECHNICAL DATA	UNIT	E-6	E-7	E-8	E-9
Max lifting movement	kNm/kgm	587	578	570	557
Slewing arc	(°)	Continuous	Continuous	Continuous	Continuous
Slewing capacity – Max slope	(°)	4,5	4,5	4,5	4,5
Max oil delivery	l/min	140	140	140	140
Weight of the crane, including stabilizers (+/- 2%)	kg	6575	6815	7040	7215
Weight of the crane with JIB, including stabilizers (+/- 2%)	kg	-	8175	8390	-
Recommended oil flow	l/m	120-140	120-140	120-140	120-140
Installation space in folding position without Jib	mm	1640	1680	1680	1680
Installation space in folding position with JIB	mm	-	2083	2083	-
Height in folding position without JIB	mm	2511	2511	2511	2511
Height in folding position with JIB	mm	-	2716	2716	-

TAKE A LOAD OF YOUR BUSINESS WITH HIPERFORM SMART SOLUTIONS

Investing in Hiab equipment ensures reliable and efficient performance, which is essential for meeting your customer commitments safely every single day. Hiab Services supports your equipment's entire lifecycle to maximise uptime and reliability.

HiPerform is a suite of smart solutions that maximise the lifecycle value of your HIAB loader crane by optimising the performance and productivity of operators, equipment and fleets. Just choose the proactive maintenance, telematics, or simulator training solutions that meet your needs.

Original Parts

Hiab Original Parts ensure that your Hiab product stays a Hiab product. Keep the same functionality and quality you invested in from the start – essential for optimal performance, maximum safety and avoiding costly downtime.



HIAB service just got smarter

HiPerform helps you plan and optimise the maintenance of your connected HIAB based on near real-time data and actual usage.

Our proactive ProCare fixed fee service contracts prevent negative surprises and ensure more planned positives while our HiConnect equipment insight solution gives you access to your equipment's service history and upcoming service needs.

Superior spare parts availability, with a dedicated team of trained professionals and a wide service network, delivers fast response and resolution. Take a load of maintenance and yourself.

All data is considered to be true at the time of issue. Product data, details and specifications might change, valid content is determined during the official ordering process.

BUILT TO PERFORM

Hiab is a leading provider of smart and sustainable load handling solutions. We are committed to delivering the best customer experience every day with the most engaged people and partners. Hiab's premium equipment includes HIAB, EFFER and ARGOS loader cranes, MOFFETT and PRINCETON truck mounted forklifts, LOGLIFT forestry cranes, JONSERED recycling cranes, MULTILIFT skiploaders and hooklifts, GALFAB roll-off cable hoists, and tail lifts under the ZEPRO, DEL and WALTCO brands. As the industry pioneer, Hiab continues to make load handling smarter, safer and more sustainable to build a better tomorrow.

hiab.com

Hiab fa parte di Cargotec Corporation.

cargotec.com

