

HIAB X-HIDUO 228



HIAB X-HIDUO 228 BASIC DATA

BASIC DATA	X-HiDuo 228 B-3	X-HiDuo 228 B-4	X-HiDuo 228 E-5	X-HiDuo 228 E-6
Mdyn	243 kNm	244 kNm	252 kNm	254 kNm
Lifting capacity (kNm)	179	170	170	166
Lifting capacity (m)	18,2	17,4	17,3	17
Lifting capacity (ADC) (kNm)	195	186	186	182
Lifting capacity (ADC) (tm)	19,9	19	19	18,6
Outreach - lifting capacity, standard (m-kg)	3,5 - 5 700	3,5 - 5 500	3,6 - 5 300	3,6 - 5 200
	4,7 - 4 150	4,7 - 4 050	4,9 - 3 850	4,9 - 3 800
	6,4 - 3 000	6,4 - 2 850	6,6 - 2 750	6,7 - 2 600
	8,4 - 2 240	8,4 - 2 100	8,6 - 2 000	8,6 - 1 880
	10,5 - 1 780	10,5 - 1 640	10,7 - 1 540	10,6 - 1 440
			12,6 - 1 360	12,7 - 1 160
	15 - 1 060	17,4 - 540	12,8 - 1 240	14,9 - 950
17,2 - 810			19 - 410	
Outreach - lifting capacity, manual extensions (kg)	12,6 - 1 400	14,8 - 1 080	17,4 - 540	19 - 410
Hydraulic outreach, standard (m)	10,8	12,9	15,1	17,3
Hydraulic boom extension (m)	5,9 m	8,0 m	10,2 m	12,4 m
Outreach, manual extensions (m)	0	0	0	0
Lifting height above installation level, (hydr/manm)	13,2 / 15,4	15,3 / 17,6	17,6 / 19,9	19,8 / 21,6
Rec. oil flow (l/min)	55 - 65	55 - 65	55 - 65	55 - 65
Working pressure (Mpa)	32,9	32,9	32,9	32,9
Oil in tank (l)	92 - 200	92 - 200	92 - 200	92 - 200
Tank capacity (l)	0 - 235	0 - 235	0 - 235	0 - 235
Slewing angle (°)	415	415	415	415
Max slope viable at full capacity (°)	6	6	5	5
Slewing torque, gross (kNm)	28,3	28,3	28,3	28,3
Slewing speed 80 (° /s)	15	15	15	15
Slewing speed (°/s)	15	15	15	15
Lifting speed at standard hydraulic outreach (m/s)	1,8	2,2	2,5	2,9
Height in folded position (mm)	2 278	2 278	2 269	2 269
Width in folded position (mm)	2 476	2 476	2 496	2 496
Install space required with hose and pipe kit (mm)	1 510	1 120	1 062	1 166
Crane in standard version without stabiliser system (kg)	2 000	2 140	2 380	2 510
Frame attachments (kg)	41 - 65	41 - 65	41 - 65	41 - 65
Stabiliser system (kg)	271 - 428	271 - 428	271 - 428	271 - 428

This table shows one example of a model, and represents some of all options available. With the opportunity to configure your crane, we can provide you with a crane perfectly tailored to your needs.

Please contact your local dealer for more information and the exact data on the variety of options we can offer.

Hiab X-HIDUO 228 E-5

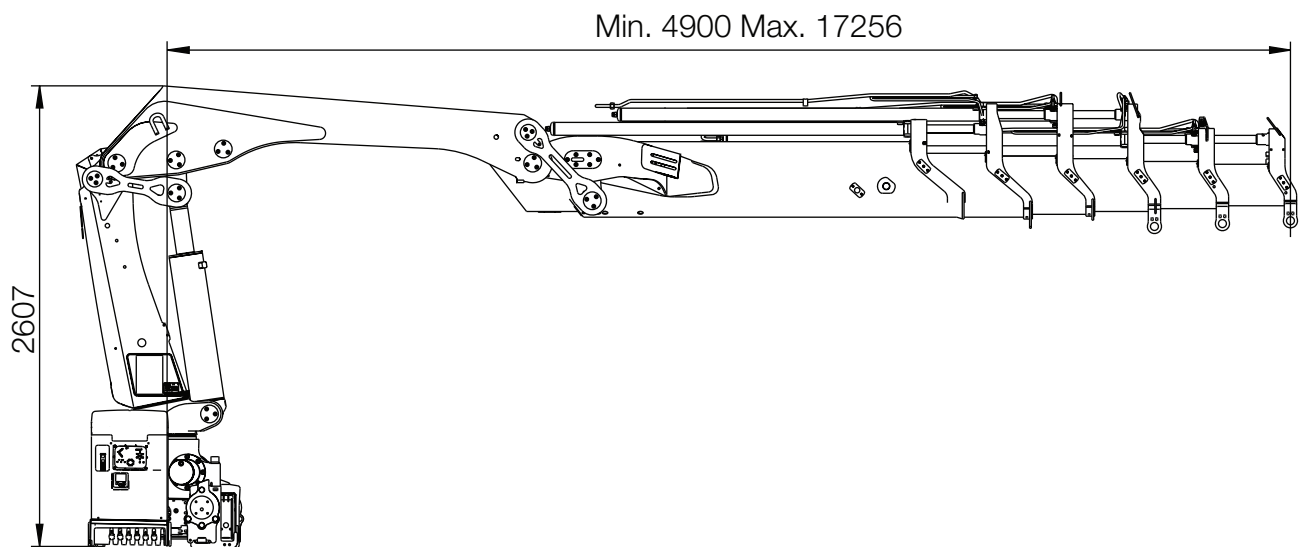
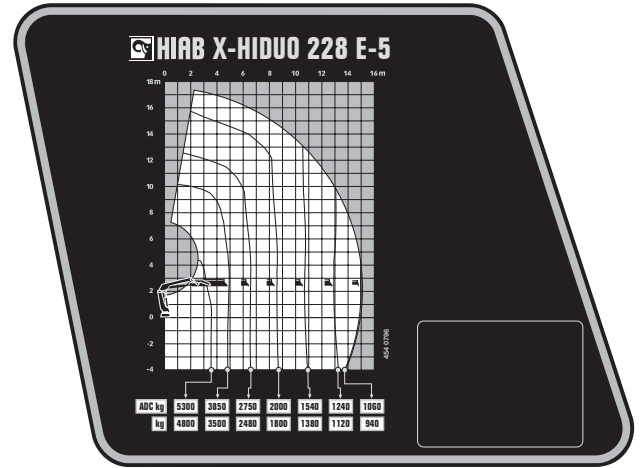
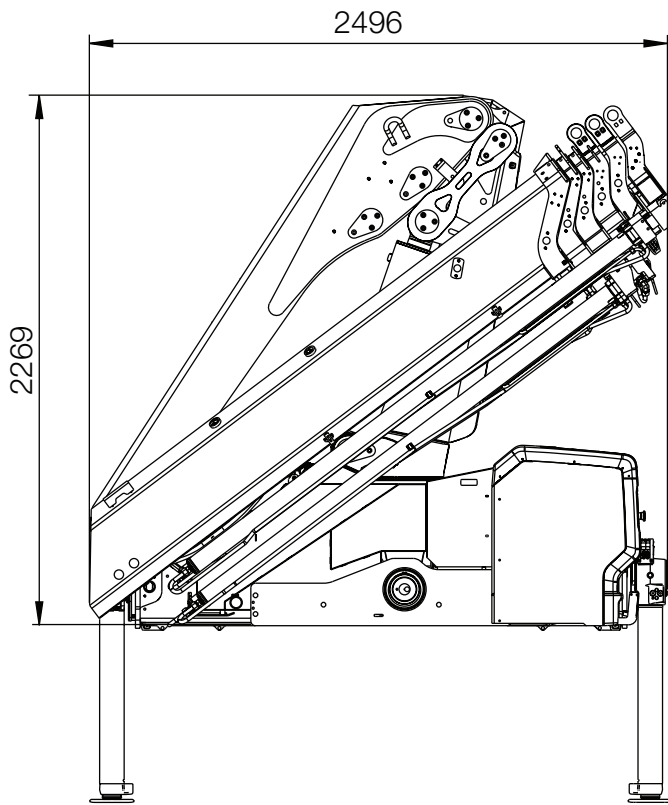

BUILT TO PERFORM

Hiab is the world's leading provider of on-road load handling equipment. Customer satisfaction is the first priority for us. Hiab's product range includes HIAB loader cranes, JONSERED recycling and forestry cranes, LOGLIFT forestry cranes, MOFFETT truck mounted forklifts and MULTILIFT demountables, as well as DEL, WALTCO and ZEPRO tail lifts.

hiab.com

Hiab is part of Cargotec.

cargotec.com



© BD-X-HIDU0228-EN-WW-201606



hiab.com