

JONSERED 1250RZ

WORK WITH EASE





BECAUSE WASTE PAYS OFF



Taking proper care of our increasing amounts of waste is important for the environment. However, turning discarded products into new raw material also means money in the bank. In order for both to happen, it is of great significance to keep the waste moving along the recycling value chain for it to be efficient and sustainable.

JONSERED 1250RZ recycling crane made for durability and tough work. It enables you to perform heavy recycling tasks easier and more efficient. This is good for your business and, at the end of the day for the environment.

EFFICIENCY AND TOUGHNESS FOR SUSTAINABLE BUSINESS

Working with recyclables is tough work and it is important that you have a high performing, speedy and durable crane. Long working days keeps your crane under continuous operation with heavy and intense load cycles. JONSERED recycling range has been developed and optimized exclusively to support you in your operation day in and day out.

Optional operators control interface

A good unobstructed view over the working area is essential when you need to get the job done quickly, efficiently and safely. Your JONSERED recycle cranes gives you a choice of different user interfaces.

- High seat, centered or side mounted for an elevated view.
- With remote control you have freedom of movement around the crane and working area enabling you to find the best possible vantage point.

Optimal weight capacity ratio

Get the most of your investment. With the optimized weight/capacity ratio the JONSERED 1250RZ can even be fitted to smaller trucks.

Hose Protection Link (HPL)

Internal hose routing

Oil

Double rack slewing

Three-point bridge

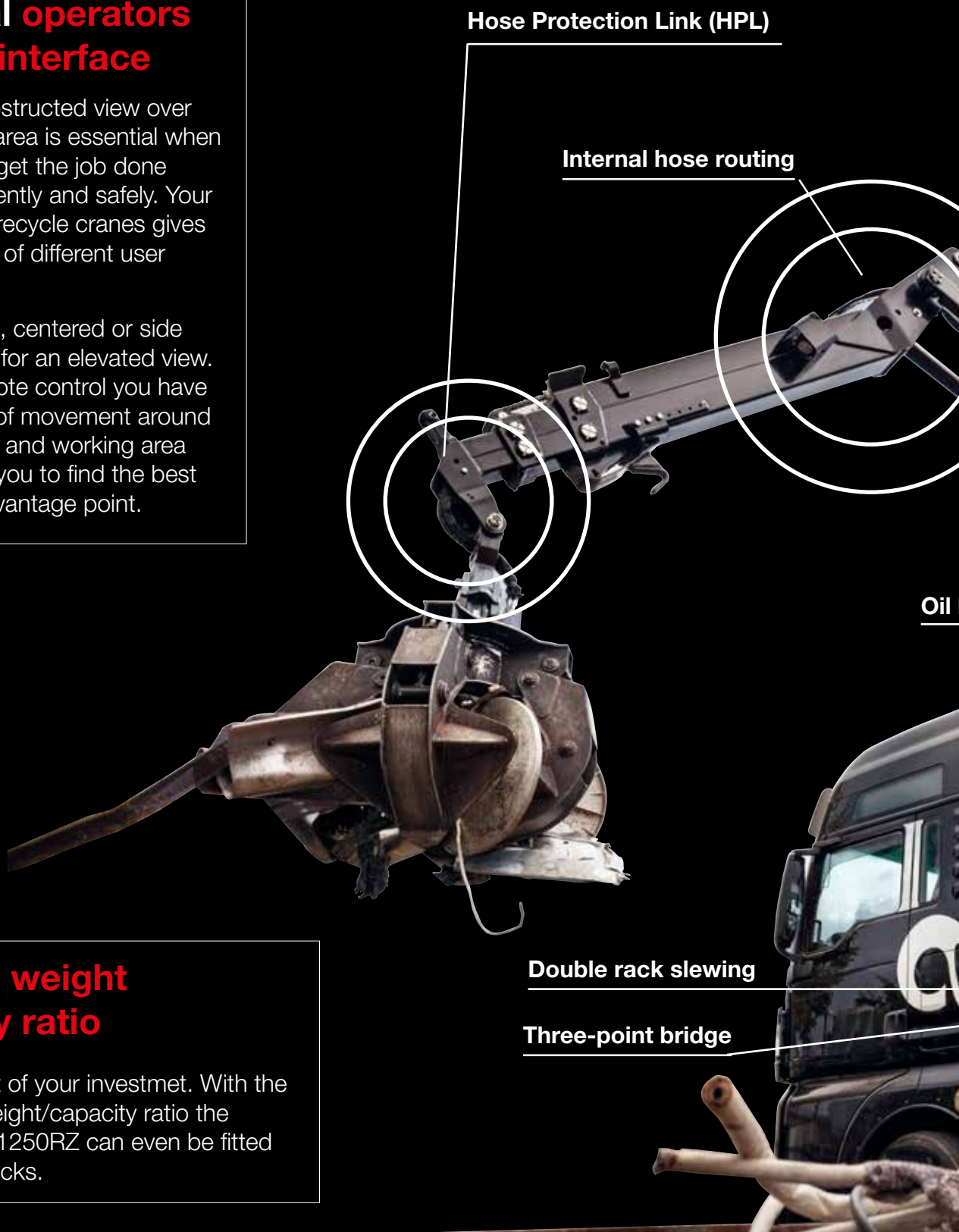

Safety systems for recycling

When it comes to keeping you and your surroundings safe at work there can be no compromises. This is one of the most important principles in Hiab.



For JONSERED cranes we have tailor made two safety systems; Safety+RS and Safety+R adapted to your operational needs to make your work as safe and efficient as possible. You continue to work efficiently while we take care of your safety.

	Safety+R	Safety+RS
Operation	High seat operation	All
Hydraulic system	Fixed	Load Sensing (LS) and Fixed
SPACE X4	No	Yes
Overload Protection	Yes	Yes
Variable Stability Logic (VSL)	On/Off	Variable
Load Holding Valve (LHV)	Yes	Yes
Pump Flow Distribution (PFD)	No	Yes
Automatic Speed Control (ASC)	No	Yes
Operator Protection System (OPS)	No	Yes

Benefits

- Stay safe with a safety system tailor made for your operational needs
- Very reliable safety systems based on Hiab quality and long experience
- A high quality safety system gives your crane a longer life
- Low risk of system damage and failure

Side supports for stability

nDurance™

nDurance

nano-technology paint process for all-weather protection

Rain, dust, sand and sunlight are unforgiving forces that wear on a crane all year around. This is why we have created nDurance — a technologically advanced and environmentally sound pre-treatment and paint process, based on nano-technology combined with state-of-the-art e-coating and powder painting.

- Nano-technology covers every square millimetre
- Three different protective layers for highest corrosion resistance
- 100 % phosphate free
- No heavy metals and virtually zero waste

VSL - for increased stability

Swivelling couplings



JONSERED 1250RZ BASIC DATA

Technical data	1250RZ 79	1250RZ 80	1250RZ 93
Max. lifting capacity (kNm)	106	110	103
Outreach, hydraulic extensions (m)	7.9	8.0	9.3
Number of extensions	2	1	2
Outreach / lifting capacity (m/kg)	3.0 - 3200 4.0 - 2550 5.0 - 2140 6.0 - 1800 7.0 - 1510 7.5 - 1400	3.0 - 3350 4.0 - 2600 5.0 - 2180 6.0 - 1880 7.0 - 1600 7.7 - 1440	3.0 - 3150 4.0 - 2460 5.0 - 2040 6.0 - 1760 7.0 - 1500 8.0 - 1300 9.0 - 970
Slewing system	Double		
Slewing angle (°)	425		
Slewing torque, gross (kNm)	28.6		
Max. working pressure (MPa)	25		
Recommended oil flow – fixed pump (l/min max)	120		
Min recommended oil flow - Variable displacement pump (l/min)	160		
Weight - High Seat crane with Standard stabilizer (kg)*	2250	2180	2320

*Weight with fixed pump system, oil weight included

Side view

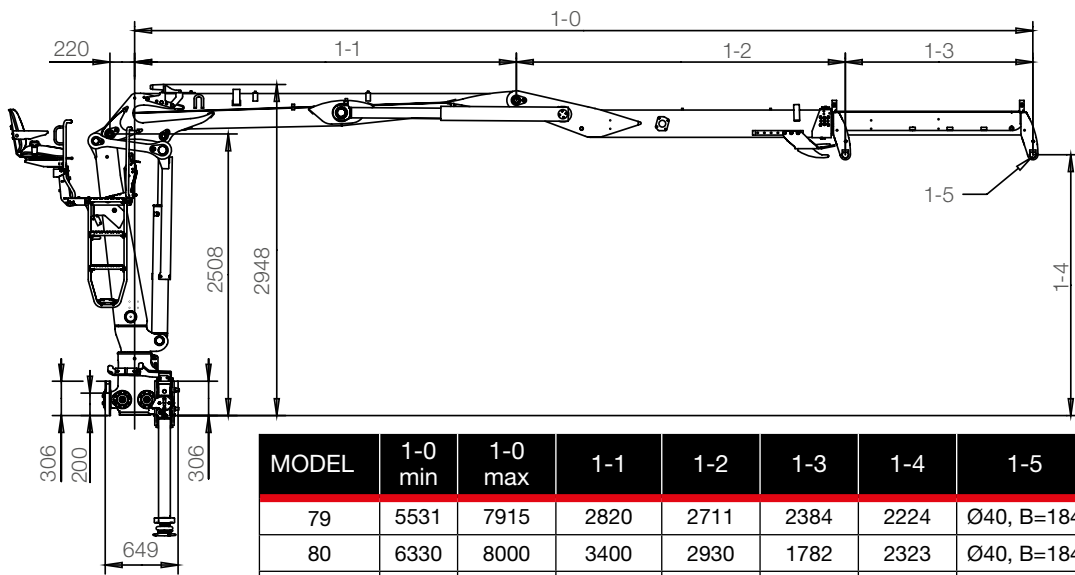

For more information,
please visit us at www.hiab.com



BUILT TO PERFORM

Hiab is the world's leading provider of on-road load handling equipment. Customer satisfaction is the first priority for us. Hiab's product range includes HIAB loader cranes, JONSERED recycling and forestry cranes, LOGLIFT forestry cranes, MOFFETT truck-mounted fork-lifts and MULTILIFT demountables, as well as DEL, WALTCO and ZEPRO tail lifts.

www.hiab.com

Hiab is part of Cargotec.

www.cargotec.com



hiab.com

