

HIAB X-CLX 248



HIAB X-CLX 248 BASIC DATA

BASIC DATA	X-CLX 248 EP-2	X-CLX 248 EP-3	X-CLX 248 EP-4	X-CLX 248 EP-5
Mdyn	280	288	294	299
Lifting capacity (kNm)	214	208	203	199
Lifting capacity (tm)	21,8			20,3
Lifting capacity (ADC) (kNm)	214	208	203	199
Lifting capacity (ADC) (tm)	21,8	21,2	20,7	20,3
Outreach - lifting capacity, standard (m-kg)	2,4 - 8 400	2,4 - 8 200	2,4 - 8 400	2,4 - 8 200
	4,2 - 5 200	4,3 - 4 950	4,4 - 4 700	4,5 - 4 500
	5,9 - 3 700	6 - 3 450	6,1 - 3 250	6,2 - 3 100
	7,9 - 2 760	8 - 2 540	8,1 - 2 380	8,2 - 2 220
		10,2 - 1 980	10,3 - 1 820	10,4 - 1 680
			12,6 - 1 460	12,7 - 1 340
				15 - 1 120
Outreach - lifting capacity, manual extensions (kg)	10,1 - 2 080	12,5 - 1 540	15 - 1 140	17,2 - 920
Hydraulic outreach, standard (m)	8	10,3	12,7	15,1
Hydraulic boom extension (m)	3,8 m	6,0 m	8,3 m	10,6 m
Outreach, manual extensions (m)	10,2	12,6	15	17,3
Lifting height above installation level, hydr/man. (m)	10,6 / 15,2	12,9 / 17,5	15,3 / 19,9	17,7 / 19,9
Rec. oil flow (l/min)	50 - 70	50 - 70	50 - 70	50 - 70
Working pressure (Mpa)	30,5	30,5	30,5	30,5
Oil in tank (l)	150 - 200	150 - 200	150 - 200	150 - 200
Tank capacity (l)	0 - 235	0 - 235	0 - 235	0 - 235
Slewing angle (°)	410	410	410	410
Max slope viable at full capacity (°)	5	5	5	5
Slewing torque, gross (kNm)	28,3	28,3	28,3	28,3
Slewing speed 80 (°/s)	15	15	15	15
Slewing speed (°/s)	15	15	15	15
Lifting speed at standard hydraulic outreach (m/s)	1,1	1,4	1,7	2
Height in folded position (mm)	2 393	2 393	2 393	2 393
Width in folded position (mm)	2 500	2 500	2 500	2 503
Install space required with hose and pipe kit (mm)	1 153	1 151	1 153	1 153
Crane in standard version without stabiliser system (kg)	2 390	56-63	2 760	2 900
Frame attachments (kg)	56 - 63	56-63	56 - 63	56 - 63
Stabiliser equipment (kg)	381 - 465	381-465	381 - 465	381 - 465

This table shows one example of a model, and represents some of all options available. With the opportunity to configure your crane, we can provide you with a crane perfectly tailored to your needs.

Please contact your local dealer for more information and the exact data on the variety of options we can offer.

Hiab X-CLX 248 EP-4

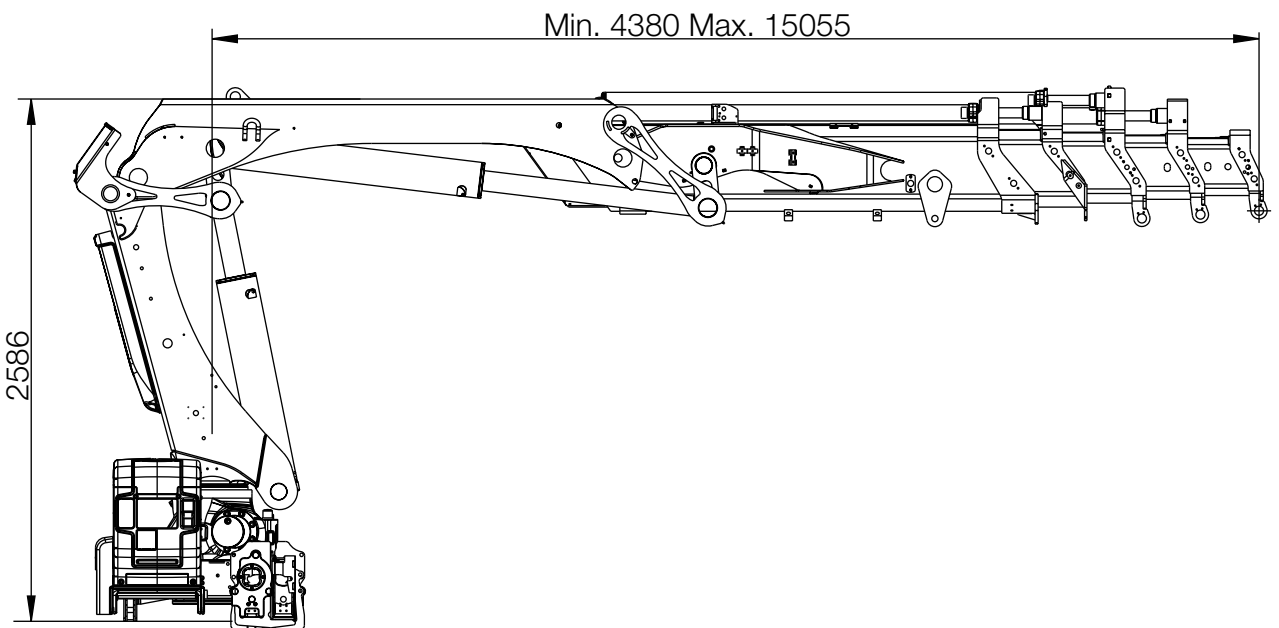
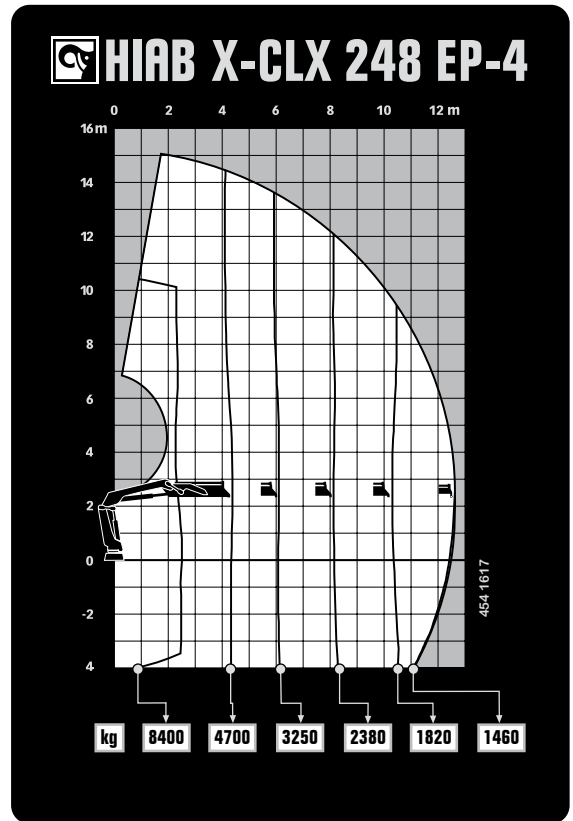
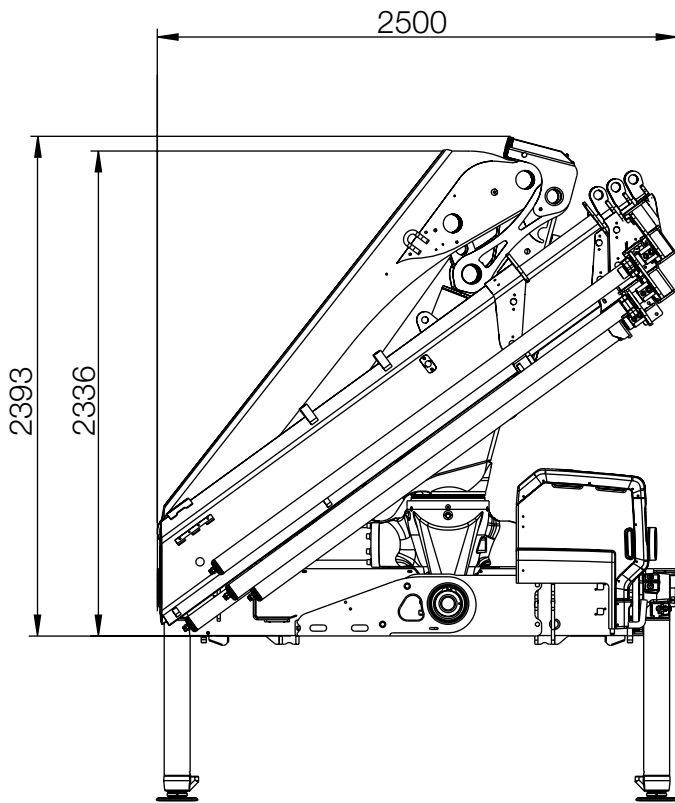

BUILT TO PERFORM

Hiab is the world's leading provider of on-road load handling equipment. Customer satisfaction is the first priority for us. Hiab's product range includes HIAB loader cranes, JONSERED recycling and forestry cranes, LOGLIFT forestry cranes, MOFFETT truck mounted forklifts and MULTILIFT demountables, as well as DEL, WALTCO and ZEPRO tail lifts.

hiab.com

Hiab is part of Cargotec.

cargotec.com



hiab.com