



iQ.1388 HI PRO

POWER FROM THE BEST OF THE BEST

The HIAB iQ.1388 HIPRO brings heavy lifting to a new level, enabling customers to operate a crane that is the engineering result of two companies that have a strong tradition in terms of know-how and experience in designing loader cranes: from the control system to one of the most performing mechanical structures.

This crane sets the standards for vertical lifting capabilities, making it a more flexible and efficient alternative to bigger and heavier cranes, but with similar performances.



An advanced structure matched to an advanced control system

Structural strength designed from HIAB combined to the group's most advanced and future forward SPACEevo system.



More performance and more payload available in a 32 GVW

The V10-Force is key to delivering 'benchmark' vertical lifts with similar performances of competitor bigger cranes, but within a footprint that leaves plenty of useful payload.



Excel in vertical reach capacity comparable with 160tm units

- Working boom angle of 83° for close work.
- 8 and 9 extension versions.
- 'Up and over' of 26m.
- Rigid boom structure for precision movements.



Fast and precise response crane movements

Assistance functions for operators:

- Confirmed View for increased operator safety.
- Fewer oscillations for more precise placement.



Powerful HD JIB capacity for delivering heavy loads at height

- HD JIB 260Q-6 contributes to being the most performing among competitors.
- JIB maximum performance 45 to 70° second boom.



Compact installation requirements for more setup flexibility options

- Closer fitting to the cabin compared to competition.
- Fits in the common 32 GVW setup, with 4 or 5 axles.
- The main boom does not go below the chassis profile for easy installations.

BUILT FOR HEAVY LIFTING APPLICATIONS

The HIAB iQ.1388 HIPRO has been designed with your business application in mind, supporting lifting activities in the most profitable manner.

- Steel structure placement
- Heavy loads and machinery
- Logistics
- MEWP operations
- Metro cities
- Glass plate handling
- Boats lifting and movement



A LAYOUT AND OPTIONS FOR A WIDE VARIETY OF USES

Choose among several options or architecture layouts to best fit your needs.

- Variants with 8 or 9 extensions in combination with JIB 6 extensions.
- HD JIB 260Q-6 (V10-Force profile shape).
- Raised hook extension.
- 3,5t Hoist.
- Ready to go preparation with Hiab FrameWorks installations and solutions division proposals.

V10 FORCE

The decagonal V10-Force boom shape, for both the crane and JIB, maximises vertical lifting capabilities while contributing in reducing the overall weight and dimension of the crane. More payload, more reach and more truck and installation alternatives.



HiConnect ready

Digitalisation and connectivity give you an added edge over competition, by handling and managing your crane, or fleet of cranes. Making decisions based on data driven information allows you to manage the daily workload and plan pre-emptively your maintenance schedules minimising downtimes.



DRIVING THE CRANE OF THE FUTURE

At the forefront of one of the most advanced operating experiences of handling a crane, is the evolution of the control system: the new SPACEevo builds on the strong legacy in terms of precision, speed and delicate movements which customers highly appreciate and benefit from during daily operations.

“iQ” range of loader crane models are the step into the future of intelligent lifting equipment.

Long lasting value

SPACEevo is an open and modular platform, that allows to add and create new functionalities over time, assuring the HIAB iQ.1388 HIPRO a long lasting operating time over the years and a higher residual value. The dual-core processor, the sensors, the actuators and the new harness design assure working in all conditions, giving power to the crane it needs, while increasing its reliability and durability for completing the most difficult jobs.



CD4 (CombiDrive4) The remote of the future

DISPLAY: Excellent control over the crane movements; data and alerts clearly readable with the new three big color displays.

PERSONALIZATION: A personalized control setting for each operator, with the use of individual batteries where the settings can be stored in the memory function so that each driver can best work according to his preferences: for example crane speed.

CONTROL: The extended battery life, the haptic feedback and the new signals complete the facility of use for the operator.

Handling a HIAB crane has never been easier, the most skilled operators will appreciate the precise and detailed movements of the crane, while those with less experience can be assisted in handling the loads in total safety and by reducing the complexity of the operations.

Discover some of the many advanced functions:

EXTRA SAFETY with Confirmed View

With the introduction of the next generation remote control CD4, the crane detects on which side the operator is compared to the crane, and it enables him to activate the stabilizers in full safety and with the complete view of their opening.

Variable Stability Logic Plus (VSL+)

VSL+ is a safety system that maximises capacity by calculating the stability according to the position of the stabiliser legs and the total weight of the truck. By accounting for the true load, it can provide significantly more lifting capacity when it really matters.

AT ITS BEST IN HEAVY VERTICAL LIFTING

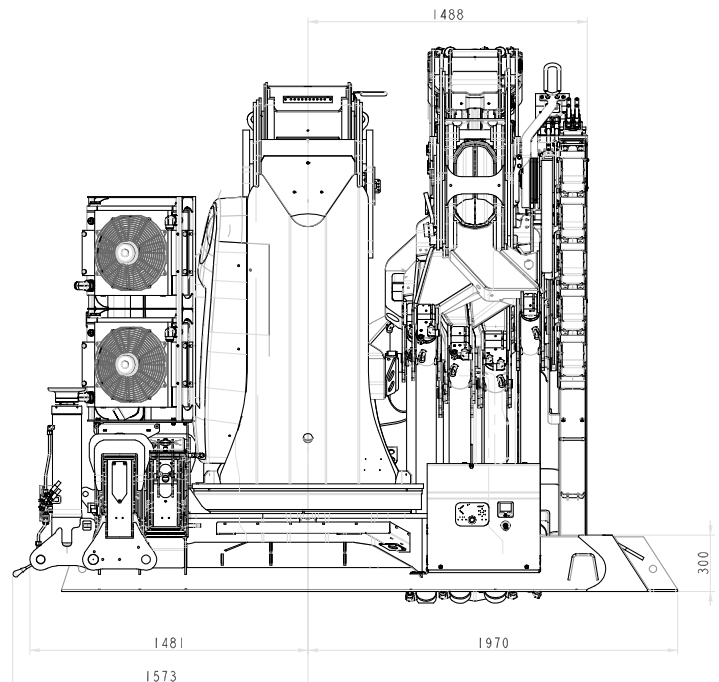
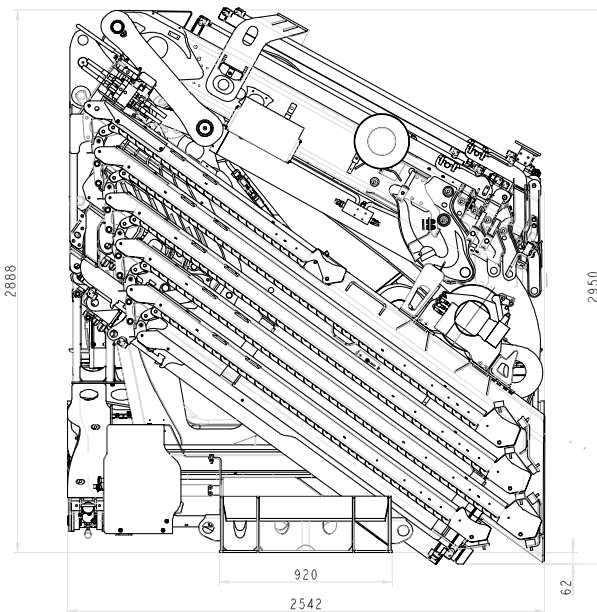
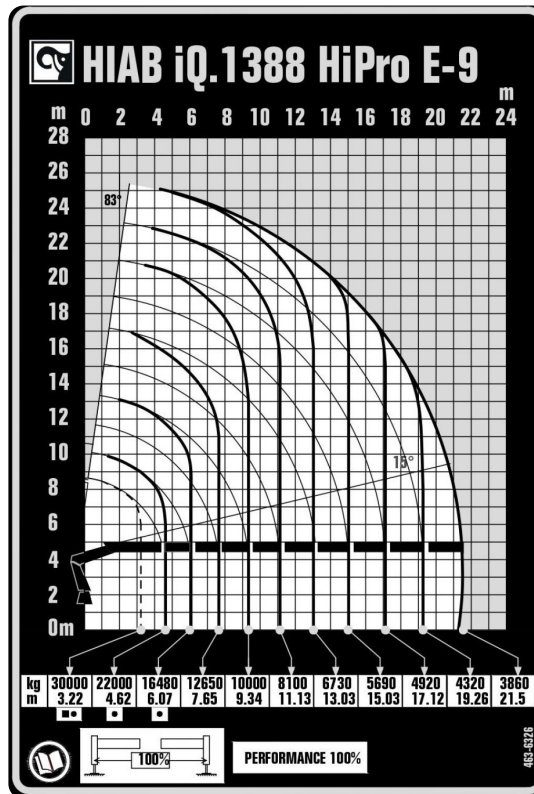
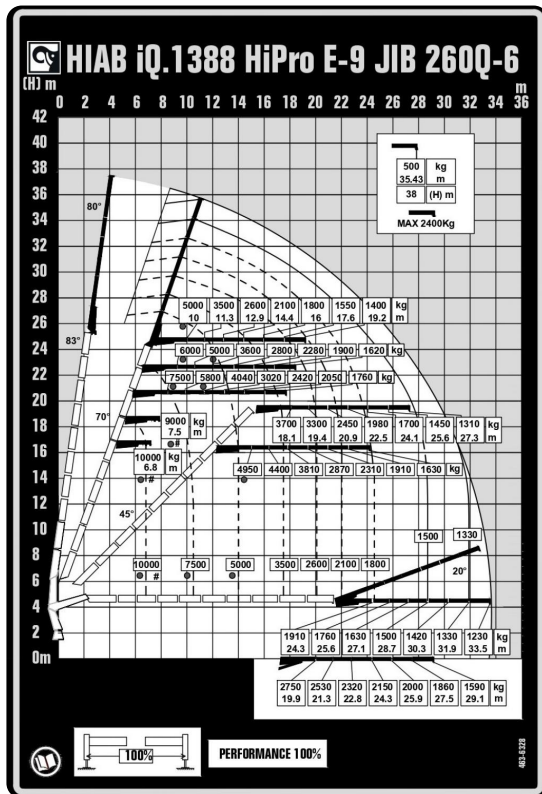

Description	Unit	E-8	E-9
Max lifting movement	kNm/kgm	993/101200	984/100280
Slewing arc	(°)	endless	endless
Slewing capacity – Max slope	%	8,7	8,7
Max oil delivery	l/min	220	220
Oil tank capacity	l	350	350
Weight of the crane (+/- 2%)	kg	12100	12400

KEEP YOUR BUSINESS MOVING WITH HIAB SERVICES

When you invest in Hiab equipment, you invest in quality performance to safely and efficiently fulfil your commitments to your customers – every single day. With Hiab Services you have access to the latest tools and connectivity solutions, quality parts and global network of experts to support you throughout your equipment's entire lifecycle, giving you the uptime and reliability you need to keep your business moving.

Original Parts

Hiab Original Parts ensure that your Hiab product stays a Hiab product. Keep the same functionality and quality you invested in from the start – essential for optimal performance, maximum safety and avoiding costly downtime.



BUILT TO PERFORM

Hiab is a leading provider of smart and sustainable load handling solutions. We are committed to delivering the best customer experience every day with the most engaged people and partners. Hiab's premium equipment includes HIAB, EFFER and ARGOS loader cranes, MOFFETT and PRINCETON truck mounted forklifts, LOGLIFT forestry cranes, JONSERED recycling cranes, MULTILIFT skiploaders and hooklifts, GALFAB roll-off cable hoists, and tail lifts under the ZEPRO, DEL and WALTCO brands. As the industry pioneer, Hiab continues to make load handling smarter, safer and more sustainable to build a better tomorrow.

hiab.com

Hiab fa parte di Cargotec Corporation.

cargotec.com

