

# HIAB X-HIPRO 192



# HIAB X-HIPRO 192 BASIC DATA

BASIC DATA	X-HiPro 192 E-3	X-HiPro 192 E-5	X-HiPro 192 E-6	X-HiPro 192 ES-2
Mdyn	214 kNm	215 kNm	216 kNm	213 kNm
Lifting capacity (kNm)	157	149	146	163
Lifting capacity (tm)	16	15,2	14,8	16,6
Lifting capacity (ADC) (kNm)	172	163	160	177
Lifting capacity (ADC) (tm)	17,5	16,6	16,3	18,1
Outreach - lifting capacity, standard (m-kg)	3,3 - 5 300	3,4 - 4 900	3,4 - 4 800	3,1 - 5 800
	4,8 - 3 650	4,9 - 3 350	5 - 3 200	4,4 - 4 100
	6,6 - 2 550	6,7 - 2 320	6,8 - 2 180	6,2 - 2 900
	8,6 - 1 920	8,7 - 1 660	8,8 - 1 540	8,2 - 2 180
		10,7 - 1 300	10,8 - 1 180	
		12,8 - 1040	12,9 - 930	
		15 - 880	15,1 - 760	
		17,4 - 650		
Outreach - lifting capacity, manual extensions (m-kg)	12,8 - 1 220	17,4 - 490	19,2 - 300	10,3 - 1660
Hydraulic outreach, standard (m)	10,8	15,2	17,5	8,3
Hydraulic boom extension (m)	6,0	10,3	12,6	3,9
Outreach, manual extensions (m)	12,9	17,5	19,3	10,5
Lifting height above installation level, hydr/man (m)	13,2 / 15,4	17,6 / 20,0	20,0 / 21,9	10,8 / 12,9
Rec. oil flow (l/min)	60 - 90	60 - 90	60 - 90	60 - 90
Working pressure (Mpa)	34,5	34,5	34,5	34,5
Oil in tank (l)	92 - 200	92 - 200	92 - 200	0 - 200
Tank capacity (l)	0 - 235	0 - 235	0 - 235	0 - 235
Slewing angle (°)	190 - 415	190 - 415	190 - 415	190 - 415
Max slope viable at full capacity (°)	5	5	5	5
Slewing torque, gross (kNm)	28,3	28,3	28,3	28,3
Slewing speed 80 (°/s)	16	16	16	16
Slewing speed (°/s)	16	16	16	16
Lifting speed at standard hydraulic outreach (m/s)	1,8	2,6	3	1,4
Height in folded position (mm)	2 260	2 260	2 265	2 260
Width in folded position (mm)	2 485	2 496	2 496	2 485
Install space required with hose and pipe kit (mm)	1 046	1 042	1 002	1 045
Crane in standard version without stabiliser system (kg)	2 095	2 375	2 495	1 935
Frame attachments (kg)	40 - 65	40 - 65	40 - 65	40 - 65
Stabiliser system (kg)	271 - 428	271 - 428	271 - 428	271 - 428

This table show one example of a model, and represents some of all options available. With the opportunity to configure your crane, we can provide you with a crane perfectly tailored to your needs.

Please contact your local dealer for more information and the exact data on the variety of options we can offer.

# Hiab X-HIPRO 192 E-5

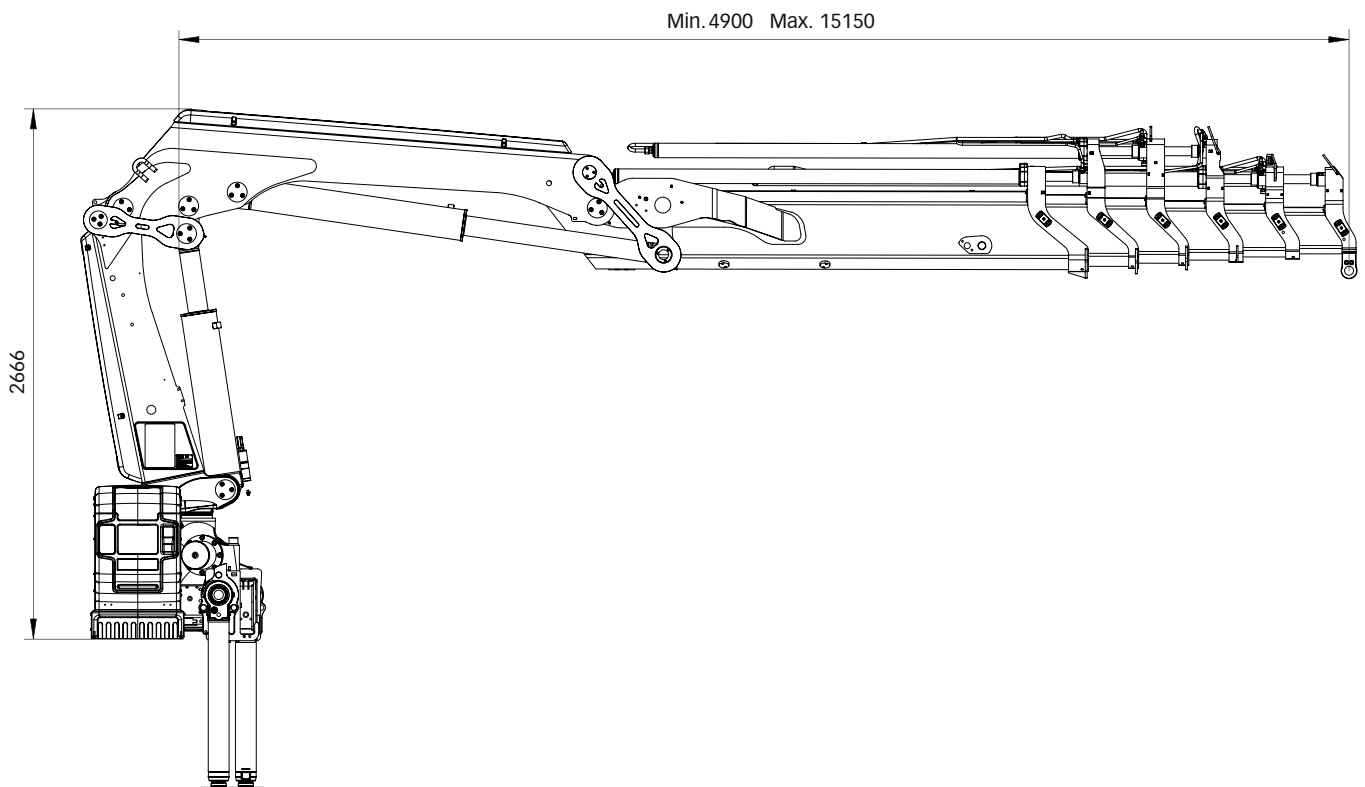
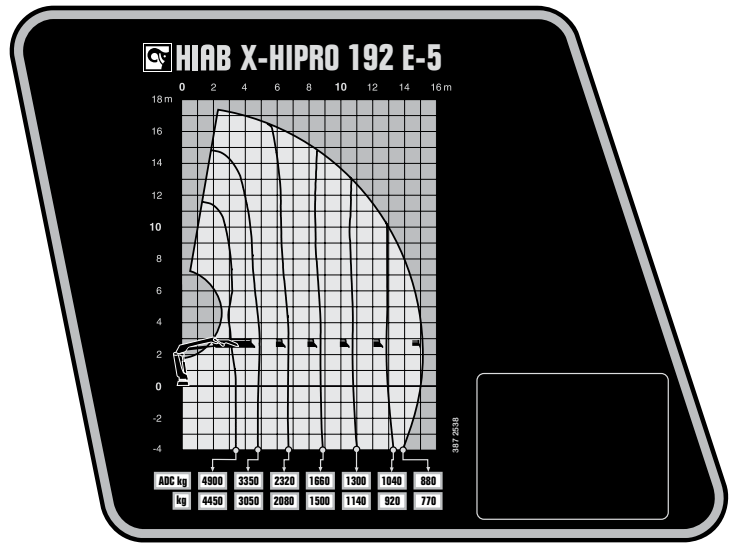
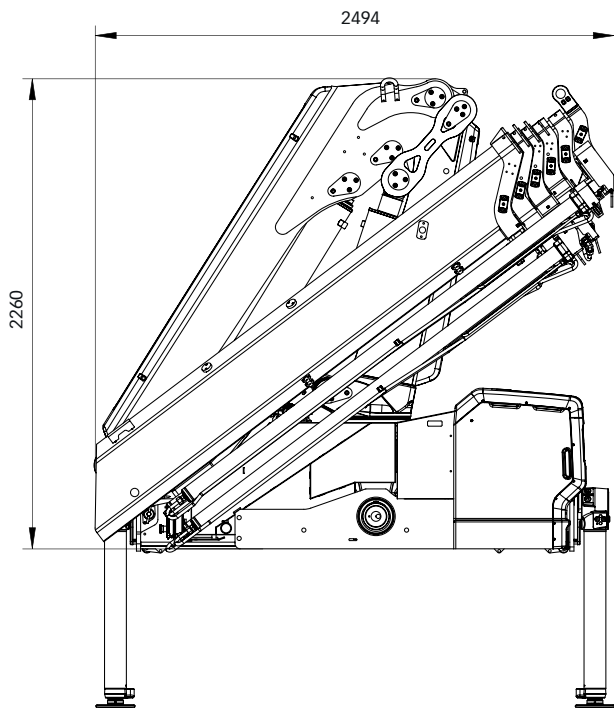

# BUILT TO PERFORM

Hiab is the world's leading provider of on-road load handling equipment. Customer satisfaction is the first priority for us. Hiab's product range includes HIAB loader cranes, JONSERED recycling and forestry cranes, LOGLIFT forestry cranes, MOFFETT truck mounted forklifts and MULTILIFT demountables, as well as DEL, WALTCO and ZEPRO tail lifts.

[hiab.com](http://hiab.com)

Hiab is part of Cargotec.

[cargotec.com](http://cargotec.com)



[hiab.com](http://hiab.com)