



NOR SERIES HD OUTSIDE RAIL HOIST

The GALFAB Heavy-Duty Outside Rail Hoist is great for severe service applications like hauling scrap, off-road or oil fields. This model has a 10" mainframe and 75k capacity making it ideal for your heaviest loads.



Visit our website: GALFAB.com | Follow us on social media



| Call Today: 574-946-7767

THE GALFAB **ADVANTAGE**



Outboard Supported Side Rollers

Greasable Roller shaft is removable with two bolts for ease of replacement and maintenance.



Wear Strips

Wear strips add strength to the hoist mainframe and this extra layer of steel protects the mainframe from wear and scuffing when loading and unloading containers.



Auto Fold Bumper

Bumper folds forward reducing the chance of bending and hang-ups in the landfill.



Container Long Sill Supports

Standard on all Outside Rail Hoists making it easier to load and unload containers.

STANDARD FEATURES

- 10" x 4" x 1/2" Main Frame tube
- 1/2 inch x 3 1/2 inch wear strip on top
- 1/2" x 4-inch stiffener on the bottom of the mainframe
- No subframe
- All Working Points Greaseable
- 2 1/2" Diameter Rear Hinge
- Pintle Ready Apron
- Auto Fold Forward DOT Bumper
- 1" Spring Loaded Container Locks
- 2 1/2" Diameter Lift Cylinder Shafts
- 12" Diameter Vertical Sheave and 10" Horizontal Sheaves
- 3/8 inch x 3-inch winch cylinder rod covers
- 6 inboard and outboard supported outside rollers
- Container long sill supports on rear of hoist mainframe
- 48 Gallon Oil Reservoir with sight and temperature gauge
- 25 Micron filtration
- Inside and Outside Controls
- LED Lighting System
- Choice of Forward or Reverse Mount single-stage or telescopic Lift Cylinders
- 7/8" Cable with Heavy Duty Swivel Eye Hook
- GALFAB auto-fold DOT bumper
- Hoist Up Alarm
- Backup Alarm

OPTIONAL FEATURES

- "The Hooker" Hold On System
- Auxilliary Stops
- Work Lights
- Behind Cab and Oversize Oil Tanks
- Tool Boxes
- Poly or Steel Fenders
- Tarping Systems
- Ratchet Tie Down Straps
- Pintle Hook
- Front Mount Pump
- PTO
- Drop Shaft
- On-Board Scale Systems
- Rear View Camera Systems



**"The Hooker"
Container
Securement System**



**Auxillary fold down
stops**



Hydraulic Reservoirs



Tool Boxes



**Poly, Steel &
Aluminum Fenders**

Shop all replacement parts at:

GALFAB.com



Visit our website: [GALFAB.com](https://www.galfab.com) | Follow us on social media



| Call Today: 574-946-7767

NOR SERIES MODELS

Model	Capacity	CA	CA with tarp	Length	Dump Angle	Up (sec)*	Down (sec)*	On (sec)*	Off (sec)*	Lift Cylinder	Winch Cylinder	Container Length ft	Apx Weight lbs
NOR60174S072	60,000	174"	186"	23'3"	48°	27	15	41	28	6" x 4" x 72" DA	7" x 4" x 79.5" DA	18'-22'	7,550
NOR60174S072R	60,000	174"	186"	23'3"	48°	27	15	41	28	6" x 4" x 72" DA	7" x 4" x 79.5" DA	18'-22'	7,550
NOR60174T121	60,000	174"	186"	23'3"	48°	35	29	41	28	6"-5"-4" x 121" DAT	7" x 4" x 79.5" DA	18'-22'	7,225
NOR75174S072F7	75,000	174"	186"	23'3"	48°	37	23	41	28	7" x 4" x 72" DA	7" x 4" x 79.5" DA	18'-22'	7,550
NOR75174S072R7	75,000	174"	186"	23'3"	48°	37	23	41	28	7" x 4" x 72" DA	7" x 4" x 79.5" DA	18'-22'	7,550
NOR75174T121	75,000	174"	186"	23'3"	48°	35	29	41	28	6"-5"-4" x 121" DAT	7" x 4" x 79.5" DA	18'-22'	7,350
NOR60194S072	60,000	194"	206"	24'11"	48°	27	15	46	31	6" x 4" x 72" DA	7" x 4" x 89.5" DA	20'-24'	7,850
NOR60194S072R	60,000	194"	206"	24'11"	48°	27	15	46	31	6" x 4" x 72" DA	7" x 4" x 89.5" DA	20'-24'	7,850
NOR60194T121	60,000	194"	206"	24'11"	48°	35	29	46	31	6"-5"-4" x 121" DAT	7" x 4" x 89.5" DA	20'-24'	8,075
NOR75194S072F7	75,000	194"	206"	24'11"	48°	37	23	46	31	7" x 4" x 72" DA	7" x 4" x 89.5" DA	20'-24'	7,850
NOR75194S072R7	75,000	194"	206"	24'11"	48°	37	23	46	31	7" x 4" x 72" DA	7" x 4" x 89.5" DA	20'-24'	7,850
NOR75194T121	75,000	194"	206"	24'11"	48°	35	29	46	31	6"-5"-4" x 121" DAT	7" x 4" x 89.5" DA	20'-24'	8,075

* Cycle Times are Factory developed and controlled by PTO output, oil viscosity, human and mechanical efficiency, and may vary accordingly.

CAUTION: This Equipment Should be Operated by Properly Trained Personnel. Improper Use, Misuse, or Lack of Maintenance Could Cause Injury to Persons or Property. Photos used in this brochure are illustrative only. We reserve the right to make changes at any time without notice. Information contained within this literature is believed to be the most accurate available at the time of printing.

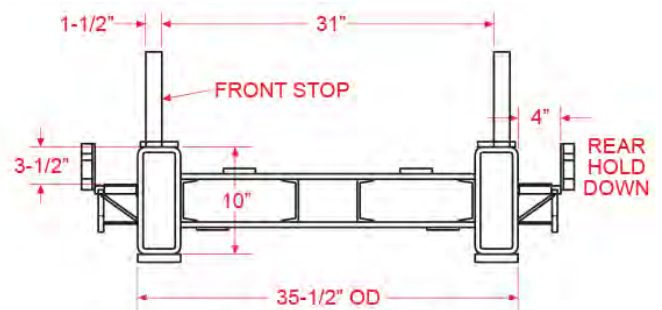
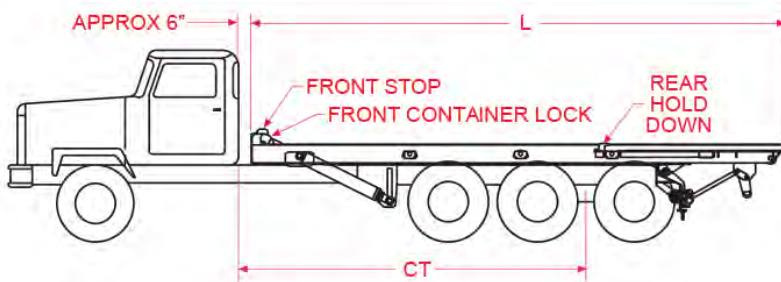

HOIST FRAME DETAILS

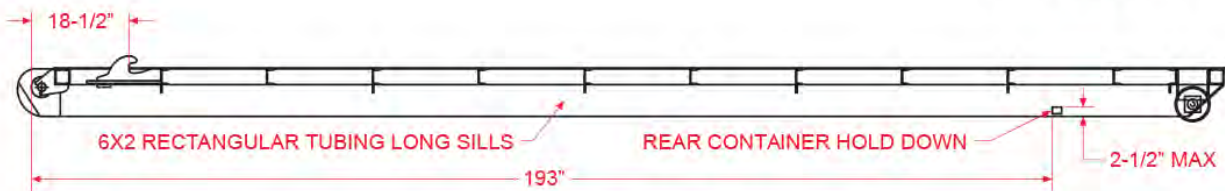

OUTSIDE RAIL CONTAINER REQUIREMENTS