



iZ.18R^{HD}

A STURDY DESIGN FOR THE MOST DEMANDING APPLICATIONS



Built for the most demanding applications

- Scrap yards and material collection from the ground..
- Car wrecks pickup in yards.
- Digging mud, soil, verge/road side and ditch waste (municipality work), biological waste.
- Underground bins handling.
- Removal concrete and heavy materials from building or restructuring sites, in combination to a tipper body.

Extend your working cycle to eight hours

The JONSERED iZ.18R HD offers customers with an eight hour working cycle use, making it adequate for demanding applications where mechanical stress of the structure are needed to carry out the job.

THE CRANE FOR DAILY WORK, OVER AND OVER

The JONSERED iZ.18R HD has been designed from the very beginning to constantly work in harsh conditions day after day while keeping business's running and growing.

Designed to be a durable and reliable product, this 18tm range recycling crane builds on proven technical solutions and its equally high quality components it's made of.



Efficiency and safety with SPACEevo

The introduction of the SPACEevo control system enhances JONSERED recycling cranes to deliver high levels of efficiency for carrying out more jobs during the day while protecting the operators and external environment.

- The open and modular platform allows users to add functions and features over time, preserving a higher residual value of the equipment.
- The high quality components, like the Olsbergs Q200 valve block, assure longer lasting operations while reducing ownership costs.
- Increased safety and increased control of the crane, with the possibility to fine tune its working movements and behavior.
- Tailor performance and fine tune settings of the many available parameters, in order to operate the crane according to your business or operator's needs.

Nano-technology paint process for all-weather protection

Rain, dust, sand and sunlight are unforgiving forces that wear on a crane all year around. This is why we have created nDurance — a technologically advanced and environmentally sound pre-treatment and paint process, based on nano-technology combined with state-of-the-art e-coating and powder painting.

- Nano-technology covers every square millimetre
- Three different protective layers for highest corrosion resistance
- 100 % phosphate free
- No heavy metals and virtually zero waste

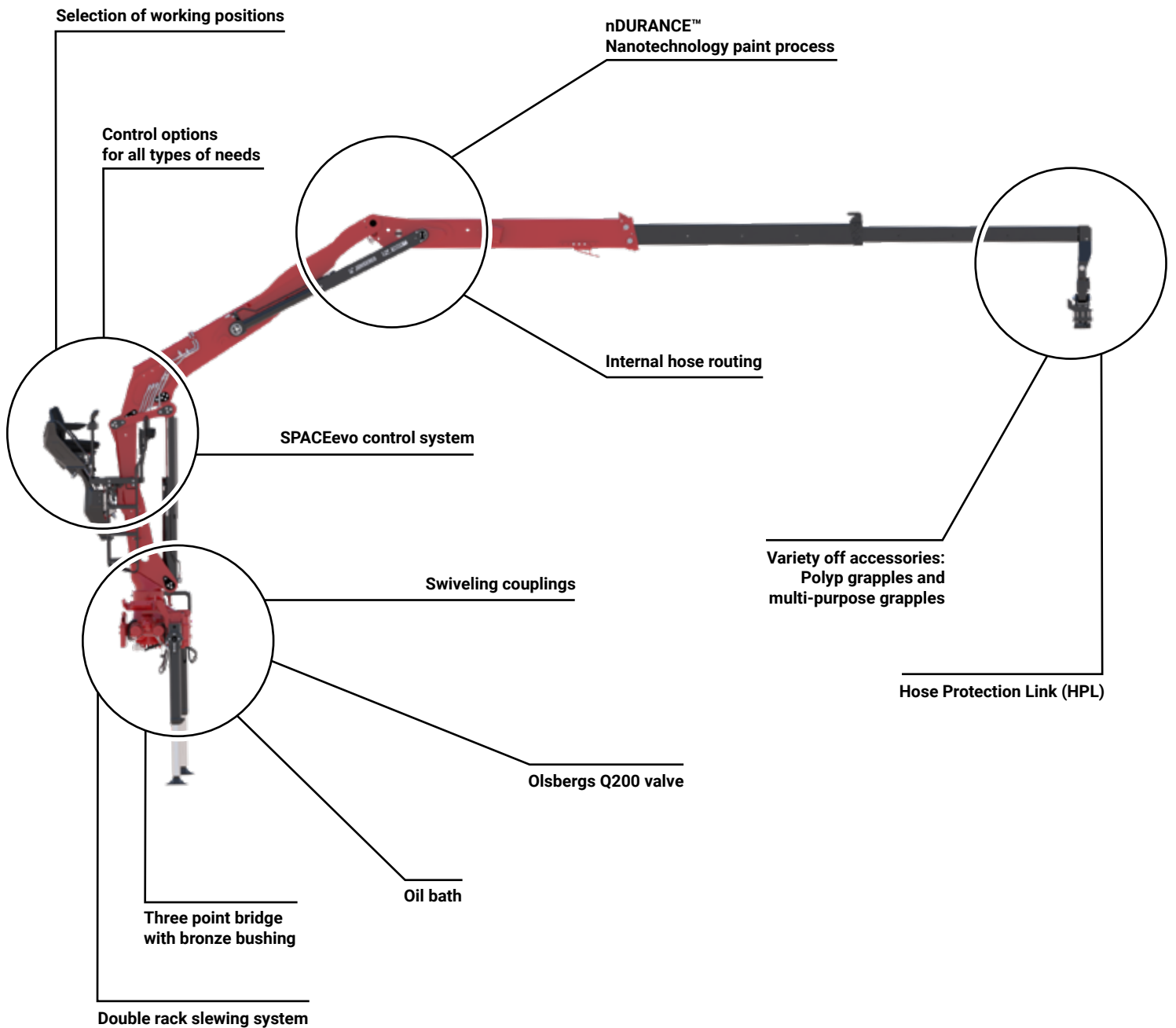

Driving the crane made easy

Control options:

- 2 mechanical levers + pedals (2+2)
- 2 electric joysticks
- Remote control

A selection of working control positions, for every operator need

Control position areas:

- High seat
- Side seat (Left & Right)
- Platform
- Cabin left side column

Quality components that make the difference

- Q200 Olsbergs main valve
- Parker P70 stabiliser valve

Easy control of setting up the working station

Stabiliser controls:

- Electric control (keypad)
- Electric control (keypad crane base)
- Electric joysticks
- Remote control

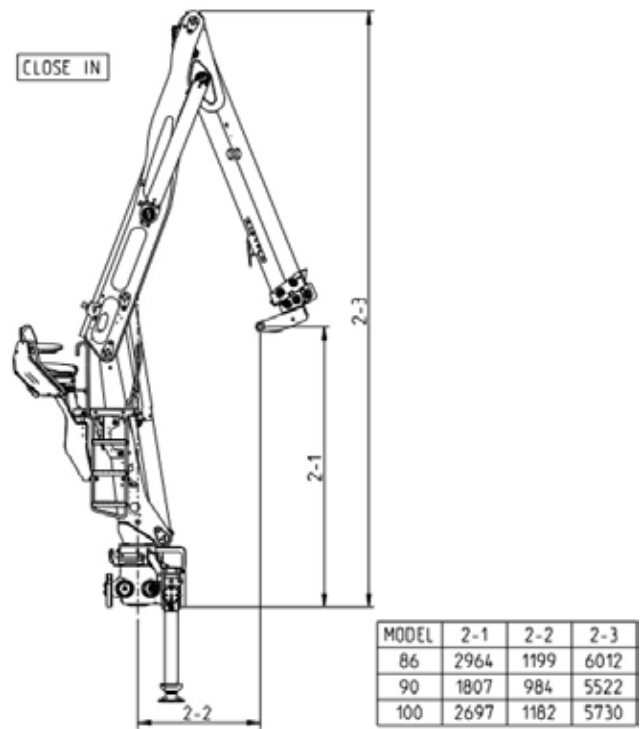
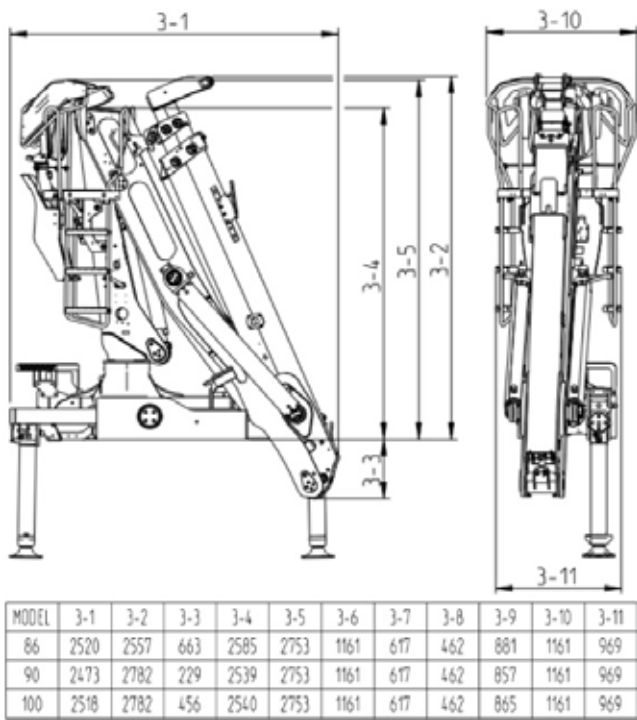

TECHNICAL DATA		iZ.18R HD 86	iZ.18R HD 90	iZ.18R HD 100
Max. lifting capacity	kNm	186	177	174
Max outreach	mm	8550	8985	9985
Hydraulic boom extension	mm	2260	3530	4030
Outreach - lifting capacity, standard	m-kg	3 - 5200 4 - 4000 5 - 3300 6 - 2800 7 - 2400 8 - 2080 8,3 - 1900	3 - 4400 4 - 3800 5 - 3400 6 - 2900 7 - 2450 8 - 2100 8,7 - 1640	3 - 3950 4 - 3400 5 - 3100 6 - 2850 7 - 2400 8 - 2040 9 - 1780 9,7 - 1400
Slewing system	-	Double		
Slewing angle	(°)	413		
Slewing torque, gross	kNm	34,6		
Max. slope viable at full capacity	(°)	5		
Max. working pressure	MPa	27		
Recommended oil flow – fixed pump, 1-pump	l/min	-		
Min. recommended oil flow – variable displacement pump	l/min	160		
Power needed at rec. oil flow - fixed pump, 1-pump	kW	-		
Power needed at min. rec. oil flow - variable displacement pump	kW	80		
Road width (without seat)	mm	2496		
Weight - Crane	stabilizers and weight oil included; without accessories			
Weight - HiSeat Crane with standard stabilizers	kg	2940	2960	3030
Weight - Cabin Crane with standard stabilizers	kg	3460	3480	3550
Weight - Wide stabilizers	kg	+80		

TAKE A LOAD OF YOUR BUSINESS WITH HIPERFORM SMART SOLUTIONS

Investing in Hiab equipment ensures reliable and efficient performance, which is essential for meeting your customer commitments safely every single day. Hiab Services supports your equipment's entire lifecycle to maximise uptime and reliability.

HiPerform is a suite of smart solutions that maximise the lifecycle value of your HIAB loader crane by optimising the performance and productivity of operators, equipment and fleets. Just choose the proactive maintenance, telematics, or simulator training solutions that meet your needs.

Original Parts

Hiab Original Parts ensure that your Hiab product stays a Hiab product. Keep the same functionality and quality you invested in from the start – essential for optimal performance, maximum safety and avoiding costly downtime.



HIAB service just got smarter

HiPerform helps you plan and optimise the maintenance of your connected HIAB based on near real-time data and actual usage.

Our proactive ProCare fixed fee service contracts prevent negative surprises and ensure more planned positives while our HiConnect equipment insight solution gives you access to your equipment's service history and upcoming service needs.

Superior spare parts availability, with a dedicated team of trained professionals and a wide service network, delivers fast response and resolution. Take a load of maintenance and yourself.

All data is considered to be true at the time of issue. Product data, details and specifications might change, valid content is determined during the official ordering process.

BUILT TO PERFORM

Hiab is a leading provider of smart and sustainable load handling solutions. We are committed to delivering the best customer experience every day with the most engaged people and partners. Hiab's premium equipment includes HIAB, EFFER and ARGOS loader cranes, MOFFETT and PRINCETON truck mounted forklifts, LOGLIFT forestry cranes, JONSERED recycling cranes, MULTILIFT skiploaders and hooklifts, GALFAB roll-off cable hoists, and tail lifts under the ZEPRO, DEL and WALTCO brands. As the industry pioneer, Hiab continues to make load handling smarter, safer and more sustainable to build a better tomorrow.

hiab.com

Hiab fa parte di Cargotec Corporation.
cargotec.com

