



**iQ.1188** HI PRO

# THE 110TM CRANE THAT DELIVERS INNOVATION FOR DOING MORE BUSINESS

HIAB iQ.1188 HIPRO has been developed from the very beginning to excel in being an 'allrounder' loader crane, with - long outreach - lifting capabilities. Both the vertical and horizontal performances have been optimized, with the possibility to add the use of the specially designed JIB.

It's a crane built and engineered to meet and beat customer expectations in terms of performance, revenue generator and operator use.

## Designed from the business

What characterizes this model is the long reach, with horizontal and vertical high performance capabilities that are the result of a design tailored for this use without compromises. The 9+6 extensions, or 10 extension layout structure turn out useful for the everyday tasks.

Driven by the end applications for which it was developed, key factors such as weight and frame size were considered crucial from the very beginning of the design phase of the HIAB iQ.1188 HIPRO.

## Augmented customer experience

At the heart of the intelligence of the crane, is the new SPACEvo control system: what was perfect got even more perfect.

The advanced functions assist the operators, even those less skilled, to avoid damage and work rapidly and efficiently: VSL+, LSS-V, SAF.

## Elevating the transporting capabilities

The innovative lightweight design, the addition of the optional Cyclone tank and the overall compact frame size, assure customers more space left for transporting materials related to their business.

This useful payload allows reducing going back and forth from the warehouse for moving materials, which translates into further fuel consumption savings, contributing to your businesses' bottomline.



# ENGINEERED TO PERFECTION

The innovative V12-Power boom shape, for both the crane and JIB, is the result of Hiab's engineering department to develop products that are suited for the application they are going to be used for. The uncompromised design delivers the highest level of heavy lifting performance in a crane of this category.



## A layout and options for a wide variety of uses

Choose among several options or architecture layouts to best fit your needs.

- 9+6 extensions.
- 10 hydraulic extensions (not in combination with the use of the JIB).
- JIB 155Q-6 (V12-Power profile shape).
- Raised hook extension.
- 3,5t Hoist.
- Ready to go preparation with Hiab FrameWorks installations and solutions division proposals.
- nDurance nano technology based coating for long lasting protection, resisting all weather conditions and guaranteeing higher residual value.

Description	Unit	E-8	E-9	E-10
Max lifting movement	kNm/kgm	835/85146	826/84229	821/83719
Slewing arc	(°)	endless	endless	endless
Slewing capacity – Max slope	%	7	7	7
Max oil delivery	l/min	140	140	140
Oil cyclon tank capacity	l	190	190	190
Oil tank capacity	l	300/400	300/400	300/400
Weight of the crane (+/- 2%)	kg	9021	9232	9407

# DRIVING THE CRANE OF THE FUTURE

At the forefront of one of the most advanced operating experiences of handling a crane, is the evolution of the control system: the new SPACEevo builds on the strong Hiab legacy in terms of precision, speed and delicate movements which customers highly appreciate and benefit from during daily operations.

**“iQ” range of loader crane models are the step into the future of intelligent lifting equipment.**

## Long lasting value

SPACEevo is an open and modular platform, that allows to add and create new functionalities over time, assuring the HIAB iQ.1188 HIPRO a long lasting operating time over the years and a higher residual value. The dual-core processor, the sensors, the actuators and the new harness design assure working in all conditions, giving power to the crane it needs, while increasing its reliability and durability for completing the most difficult jobs.



## CD4 The remote of the future

**DISPLAY:** Excellent control over the crane movements; data and alerts clearly readable with the new three big color displays.

**PERSONALIZATION:** A personalized control setting for each operator, with the use of individual batteries where the settings can be stored in the memory function so that each driver can best work according to his preferences: for example crane speed.

**CONTROL:** The extended battery life, the haptic feedback and the new signals complete the facility of use for the operator.

Handling a HIAB crane has never been easier, the most skilled operators will appreciate the precise and detailed movements of the crane, while those with less experienced can be assisted in handling the loads in total safety and by reducing the complexity of the operations.

## Discover some of the many advanced functions:

### EXTRA SAFETY with Confirmed View

With the introduction of the next generation remote control CD4, the crane detects on which side the operator is compared to the crane, and it enables him to activate the stabilizers in full safety and with the complete view of their opening.

### Variable Stability Logic Plus (VSL+)

VSL+ is a safety system that maximises capacity by calculating the stability according to the position of the stabiliser legs and the total weight of the truck. By accounting for the true load, it can provide significantly more lifting capacity when it really matters.



## HiConnect ready

Digitalisation and connectivity give you an added edge over competition, by handling and managing your crane, or fleet of cranes. Making decisions based on data driven information allows to you to manage the daily workload and plan pre-emptively your maintenance schedules so to minimize downtimes.



# A COMPACT AND LIGHT DESIGN FOR YOUR APPLICATION

Extra payload and transport capabilities are key HIAB iQ.1188 HIPRO features, that every customer can take advantage of, when using for a wide variety of industry uses: *glass plate handling, cabin and container placement, steel structure displacement, heavy loads and machinery movement, highway maintenance, bridge inspections and general logistics.*

E-8

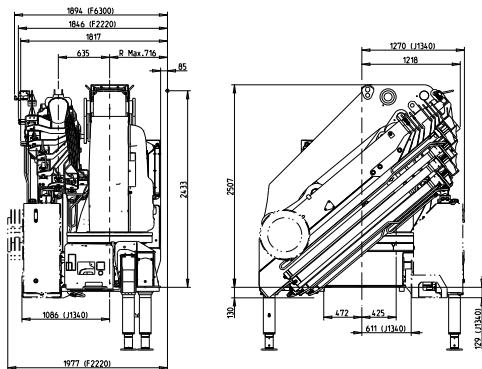

E-9

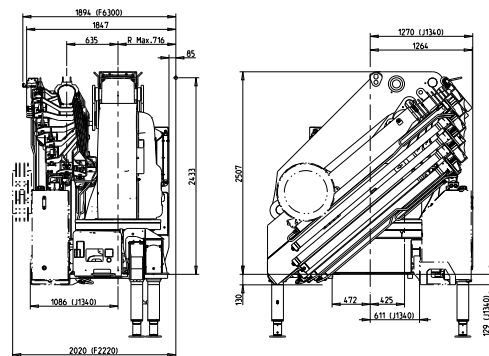

E-10

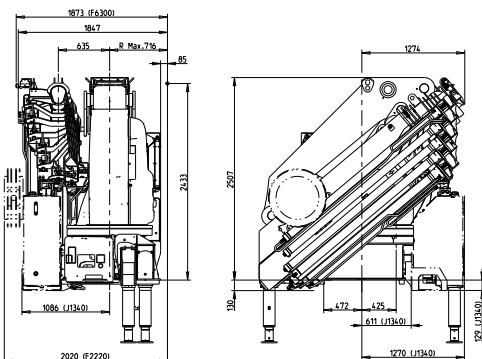

E-9 with JIB 155Q-6

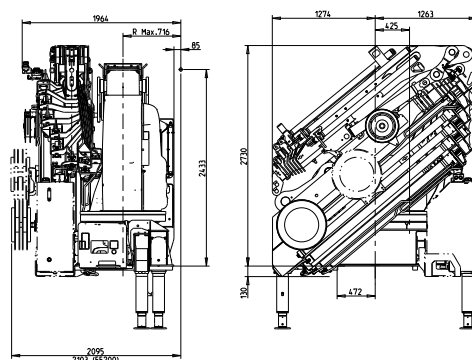

# HORIZONTAL AND VERTICAL LONG REACH PERFORMER

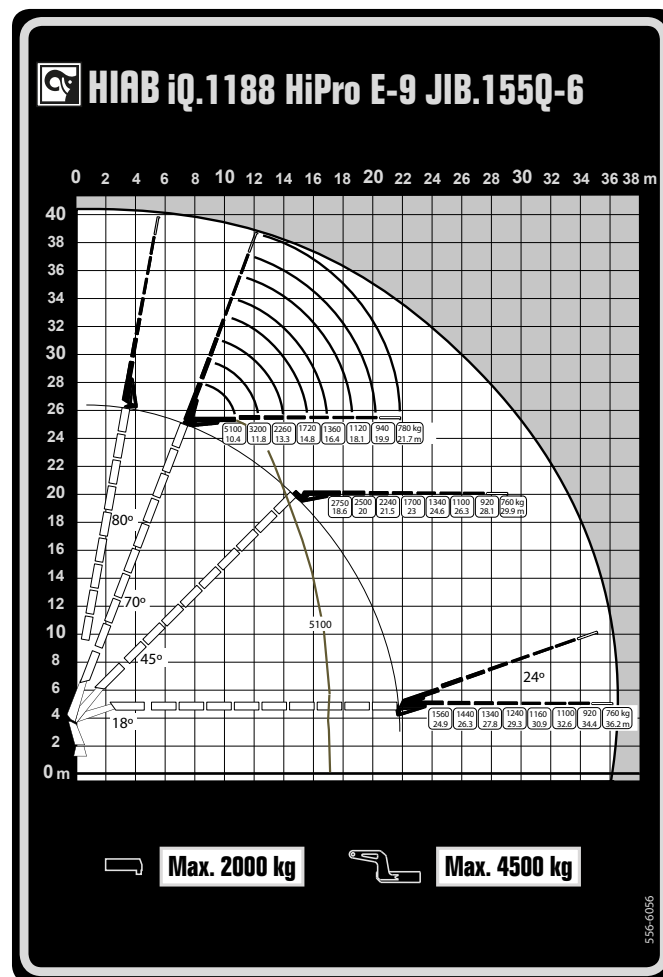
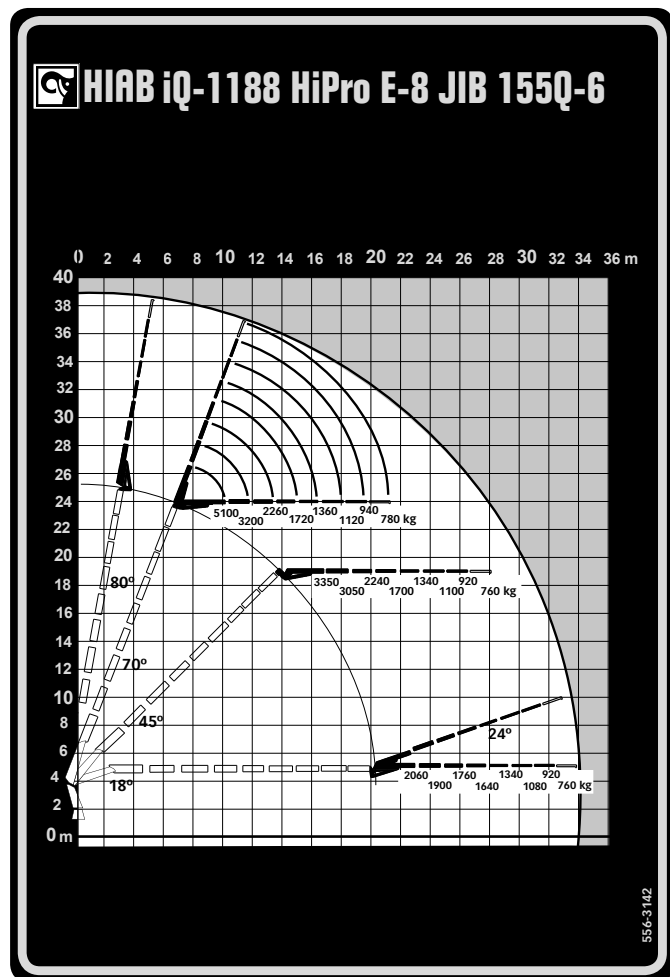
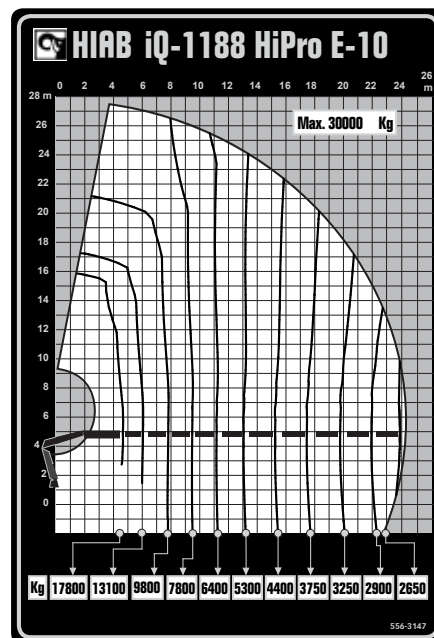
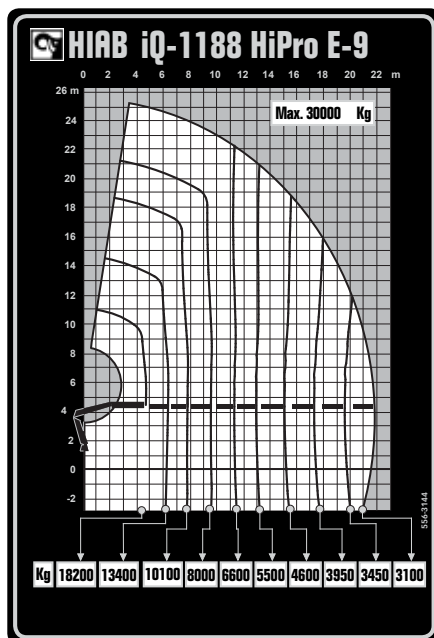
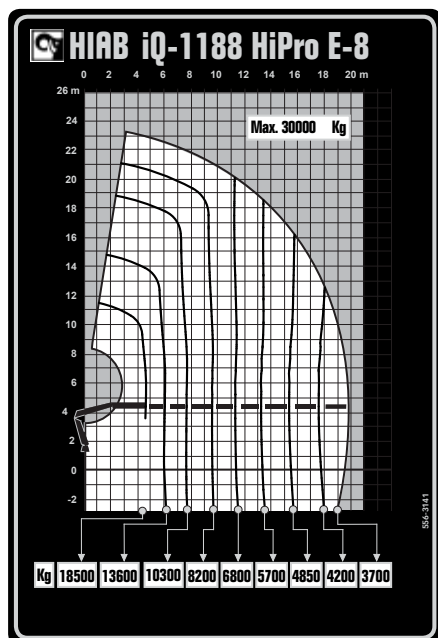

# KEEP YOUR BUSINESS MOVING WITH HIAB SERVICES

When you invest in Hiab equipment, you invest in quality performance to safely and efficiently fulfil your commitments to your customers – every single day. With Hiab Services you have access to the latest tools and connectivity solutions, quality parts and global network of experts to support you throughout your equipment's entire lifecycle, giving you the uptime and reliability you need to keep your business moving.

## Original Parts

Hiab Original Parts ensure that your Hiab product stays a Hiab product. Keep the same functionality and quality you invested in from the start – essential for optimal performance, maximum safety and avoiding costly downtime.



# HIAB PROCARE™

Hiab ProCare is a flexible service contract designed to secure the uptime of all Hiab equipment by reducing the risk of costly breakdowns and unexpected downtime. Choose between Extended warranty, Essential or Total R&M (Repair & Maintenance) depending on the options and level of service that best suit your needs.

Hiab ProCare brings you even more peace of mind by reducing total cost of ownership and increasing the resale value of your machine. Let us take care of all scheduling, maintenance and inspections to help ensure that your equipment retains the same high quality you invested in. To see how Hiab Procure can work for you, please contact your local Hiab office in your country.

For contact details, go to [www.hiab.com](http://www.hiab.com)



**WELCOME TO OUR  
GLOBAL NETWORK  
PROVIDING LOCAL  
SERVICE**



All data is considered to be true at the time of issue. Product data, details and specifications might change, valid content is determined during the official ordering process.

## BUILT TO PERFORM

Hiab is a leading provider of smart and sustainable load handling solutions. We are committed to delivering the best customer experience every day with the most engaged people and partners. Hiab's premium equipment includes HIAB, EFFER and ARGOS loader cranes, MOFFETT and PRINCETON truck mounted forklifts, LOGLIFT forestry cranes, JONSERED recycling cranes, MULTILIFT skiploaders and hooklifts, GALFAB roll-off cable hoists, tail lifts under the ZEPRO, DEL and WALTCO brands, and HIPERFORM, a suite of smart solutions. As the industry pioneer, Hiab continues to make load handling smarter, safer and more sustainable to build a better tomorrow. Hiab is part of Cargotec Corporation.

[hiab.com](http://hiab.com)

Hiab is part of Cargotec Corporation.

[cargotec.com](http://cargotec.com)

