

Installation Manual

WDV & WDVBG

3500 - 6600 lb. Capacity Rail Liftgates

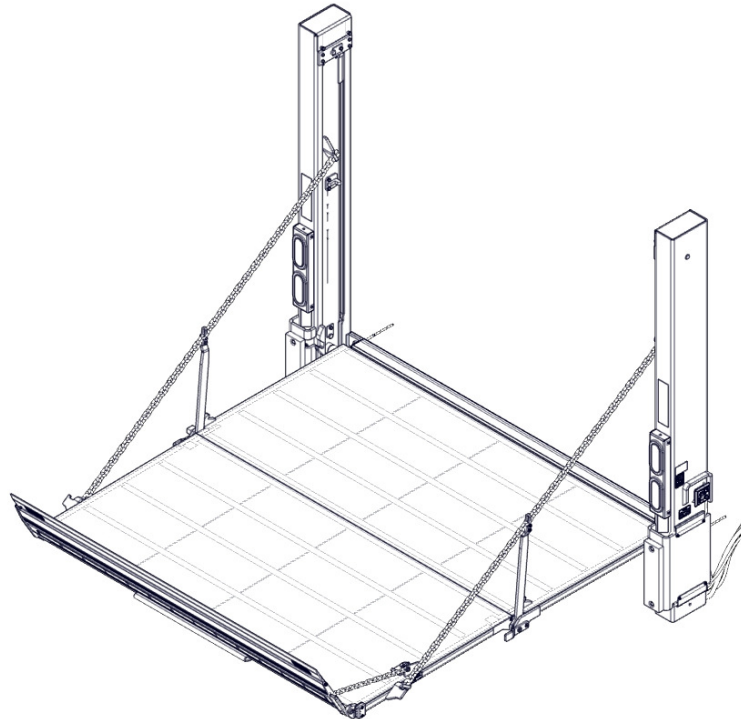

Last Change:

Date	Page(s)	Description
04/2017	11,19,29,30,44	ADDED INSTALLATION INSTRUCTIONS FOR NON-TELESCOPING HEADER REVISED WELDING PROCEDURE FOR OUTSIDE WELDS TO VEHICLE

Waltco Lift Corp.
Corporate Office United State
285 Northeast Ave.
Tallmadge, OH 44278
P: 330.633.9191
F: 330.633.1418

Waltco Lift Corp.
United States
620 S Hambledon Ave.
City of Industry, CA 91744
P: 626.964.0990
F: 626.964.0149

Waltco Lift Inc.
Canada
90 North Queen St.
Etobicoke, ON M8Z 2C5
P: 888-343.4550

Table of Contents



Improper installation of this liftgate could result in severe personal injury or death.

Read and understand the contents of these instructions before proceeding.

When installed, this liftgate must not alter or prevent vehicle compliance to any existing state or federal standards.

Each chassis manufacturer's recommendations should be consulted for compliance.

Introduction	3
Safety Information.....	4
Liftgate Terminology	6
Basic Mounting Requirements	10
Installation.....	14
Placement of Decals	40
Lubrication Instructions	41
Final Inspection	42
How to Order Parts	43
 <u>Optional Kit Instructions:</u>	
Header Kits	48
Store Below Option Kit.....	50
Kit #80001261	
Remote Switch Kit.....	53
Kit #80000438	

Chapter 2 Liftgate Terminology

- | | | |
|------------------------|-------------------------|--------------------------------|
| 1. Curb Side Column | 5. Sill Extension | 13. Curb Side Runner |
| 2. Drivers Side Column | 6. Support Chain | 14. Outside Column Switches |
| 3. Lights | 7. Swing Arm | 15. Closing Cylinder |
| 4. Inside Switch | 8. Bottom Stop Catch | 16. Drivers Side Lift Cylinder |
| | 9. Deck | 17. Curb Side Lift Cylinder |
| | 10. Deck Extension | 18. Specification Tag |
| | 11. Flip Ramp Assembly | 19. Dock Bumper |
| | 12. Drivers Side Runner | |

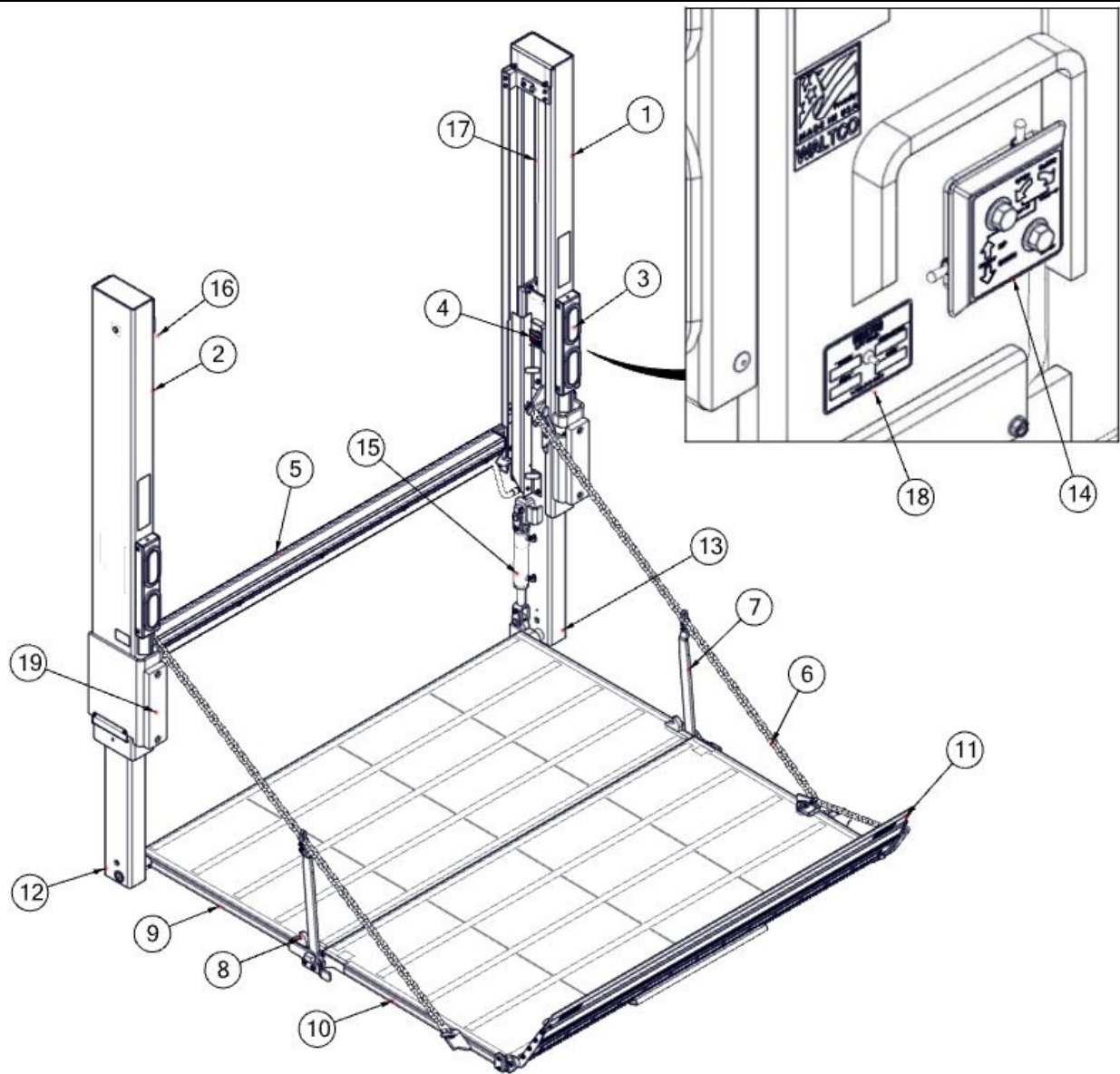

Chapter 2 Liftgate Terminology

- 20. Pump Box Lid
- 21. Battery Box Lid
- 22. Pump Box Base
- 23. Battery Box Base
- 24. Primary Motor and Pump
- 25. Backup Motor and Pump
- 26. Manifold Block Assembly
- 27. Backup Controls

- 28. 150 AMP Manual Reset Breaker
- 29. 150 AMP Auto Reset Breaker
- 30. 15 AMP Auto Reset Breaker
- 31. Master Disconnect Switch

Note: Dual motor power box is shown

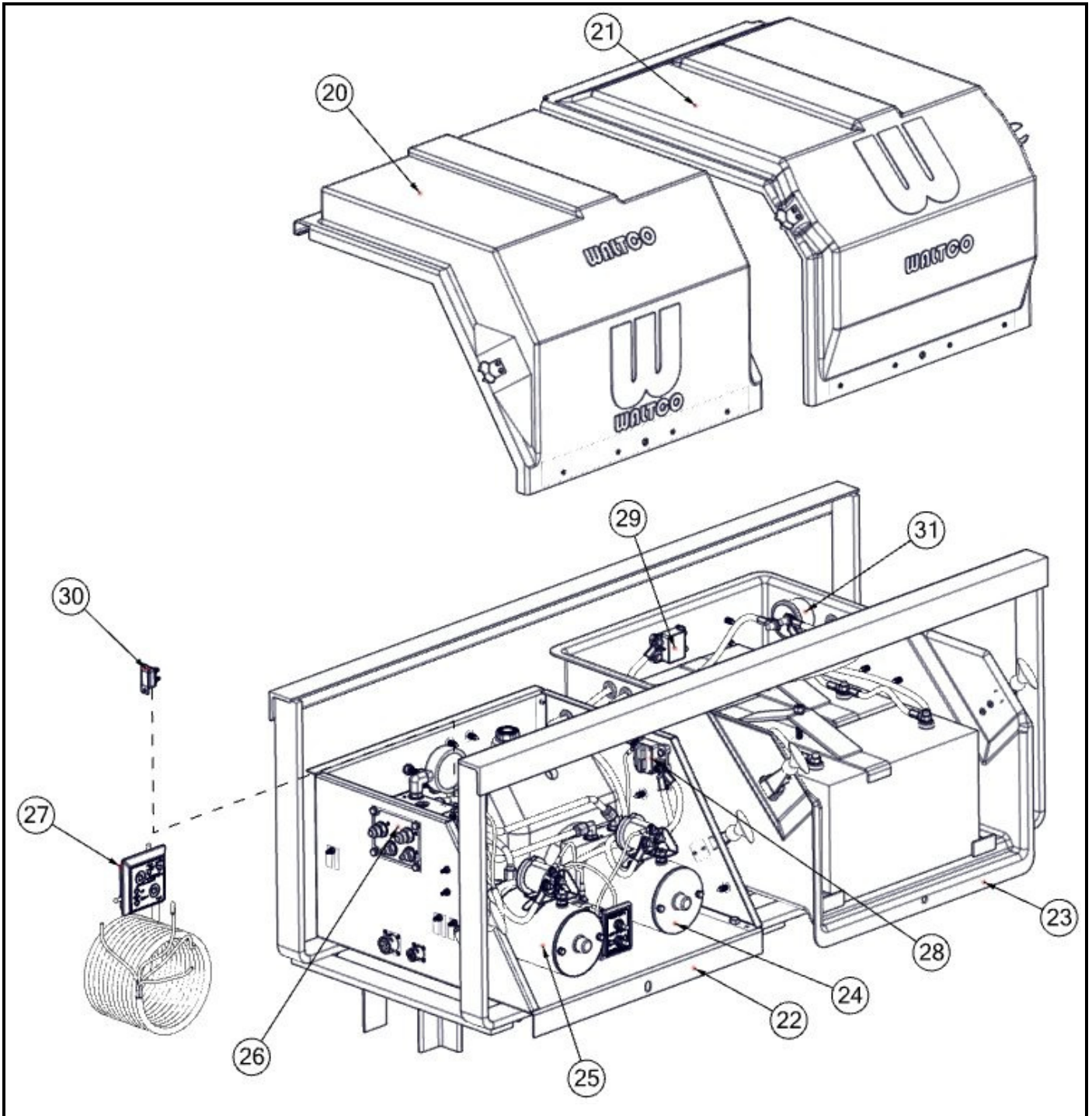

Chapter 2 Liftgate Terminology

32. Side Rail Assembly

33. Outer Guard Rail Assembly

34. Guard Rail Latch Assembly

35. Inner Guard Rail Assembly

36. Ramp Assembly

37. Gas Bottle Retention Chain

WDVBG

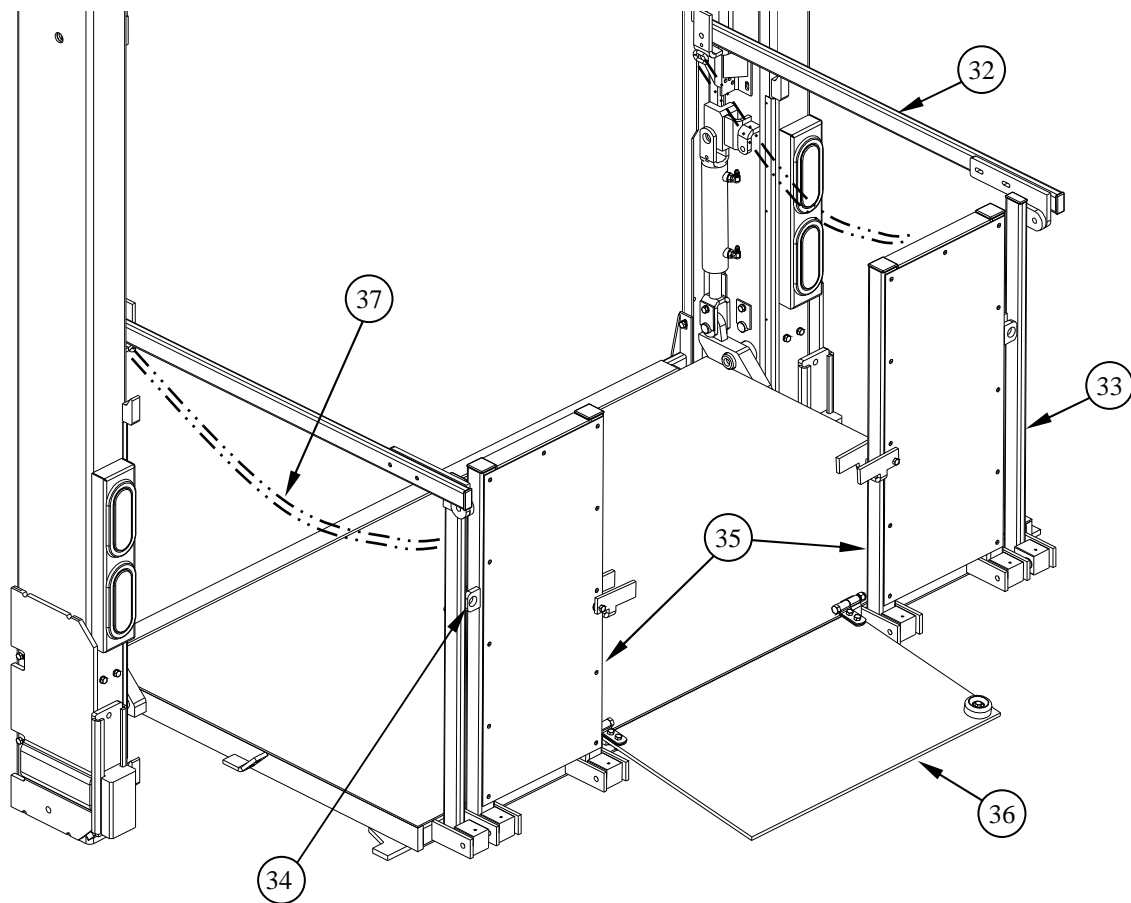

GR02366

Chapter 2 Liftgate Terminology

EXPLANATION OF SPECIFICATION TAG		
MODEL No.	DESCRIPTION	CAPACITY
WDVBG35	WDVBG-35 Series	3500 lb.
WDVBG45	WDVBG-45 Series	4500 lb.
WDV35	WDV-35 Series	3500 lb.
WDV45	WDV-45 Series	4500 lb.
WDV55	WDV-55 Series	5500 lb.
WDV66	WDV-66 Series	6600 lb.

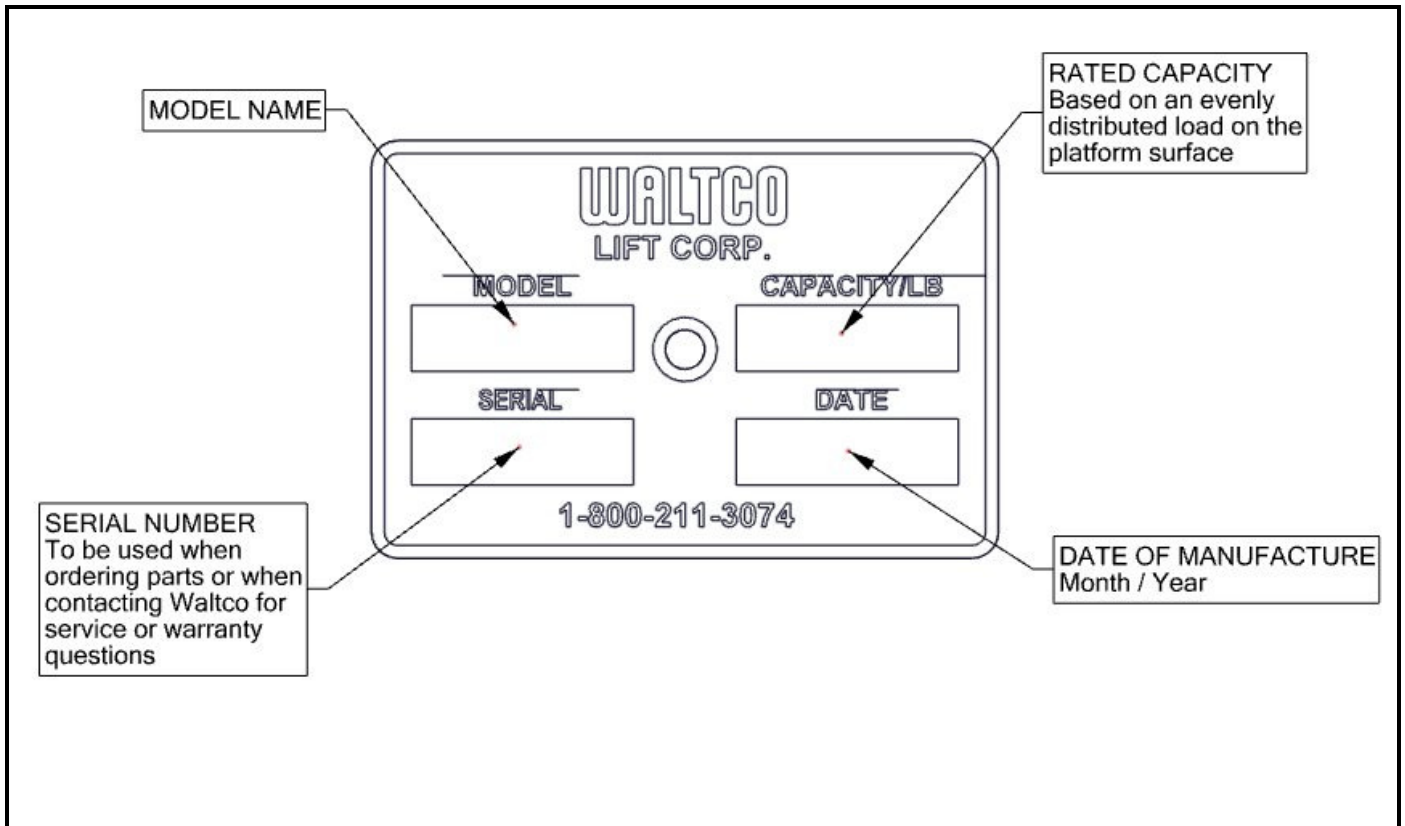

Chapter 3 Basic Mounting Requirements

MOUNTING DIMENSIONS

Determine bed height by taking the measurement from the ground to the floor level of the vehicle.

See chart below for bed height requirements and dock loading capabilities.

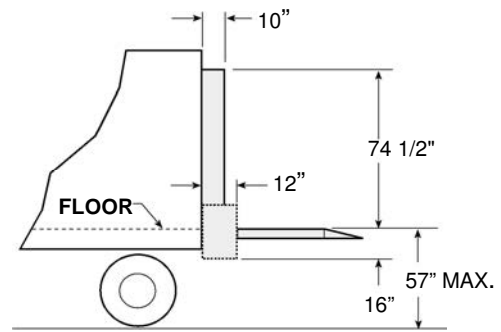

GR01561

Platform Depth	Bed Height			
	Bed Height Range Without Dock Loading Capability		Bed Height Range With Dock Loading Capability	
	Minimum	Maximum	Minimum	Maximum
36" + 16" Ramp	34"	57"	40"	57"
42" + 16" Ramp	34"	57"	46"	57"
42" Butt End	34"	57"	46"	57"
42" + 6"	34"	57"	52"	57"
60" Butt End	34"	57"	34"	57"
60" + 12" Ramp	34"	57"	42"	57"
72" Butt End	34"	57"	42"	57"
72" + 12" Ramp	34"	57"	47"	57"
86" Butt End	34"	57"	47"	57"

The WDV is offered in two widths. 96" over all width for 82" wide platforms and 102" over all width for 88" wide platforms.

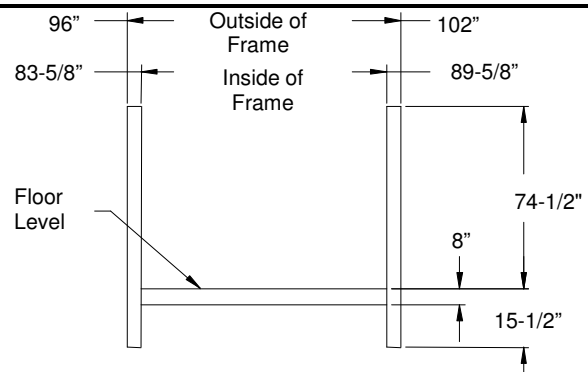

GR01562

Vehicles must be capable of supporting forces shown.

X = Each side wall tension

Y = Each side wall compression

Z = Each side wall shear

Model	X & Y lbs.	Z lbs.
WDV35, WDVBG35	2250	3500
WDV45, WDVBG45	2500	4500
WDV55	3000	5500
WDV66	3500	6600

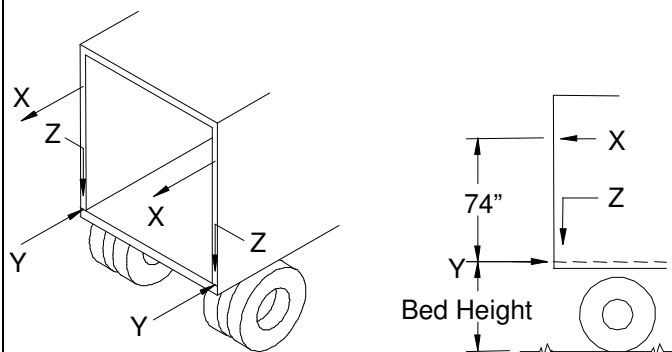

GR01563

Chapter 3 Basic Mounting Requirements

INSTALLATION OF PRE-SHIPED BOLT ON BRACKETS

NOTE: Liftgates with bolt-on brackets installed on the lift do not need to do this step. Proceed to Chapter 4.

1. Mark centerline of sill. Mark the centerline of the extended threshold.
2. Position top of extended threshold flush with top of rear sill and centered on trailer using marks previously made.
3. Clamp threshold extension to sill and tack weld in position.
4. Orient the mounting brackets such that the tandem holes properly located towards the top as shown below.
5. Clamp mounting bracket to rear of trailer at dimensions shown below so that they can still be adjusted.
6. Measure corner to corner in both directions. Dimensions should be within 1/16". Adjust mounting brackets to achieve squareness.
7. Align holes of both mounting brackets with straight edge across the entire width of trailer as show in section D-D. Shim between brackets and rear of trailer where needed to achieve straightness.
8. Firmly clamp the mounting brackets to the rear of the trailer.
9. Tack both sides of the brackets to prevent weld draw, then weld the brackets to the rear of trailer.
10. Weld extended threshold to the rear of trailer as shown.

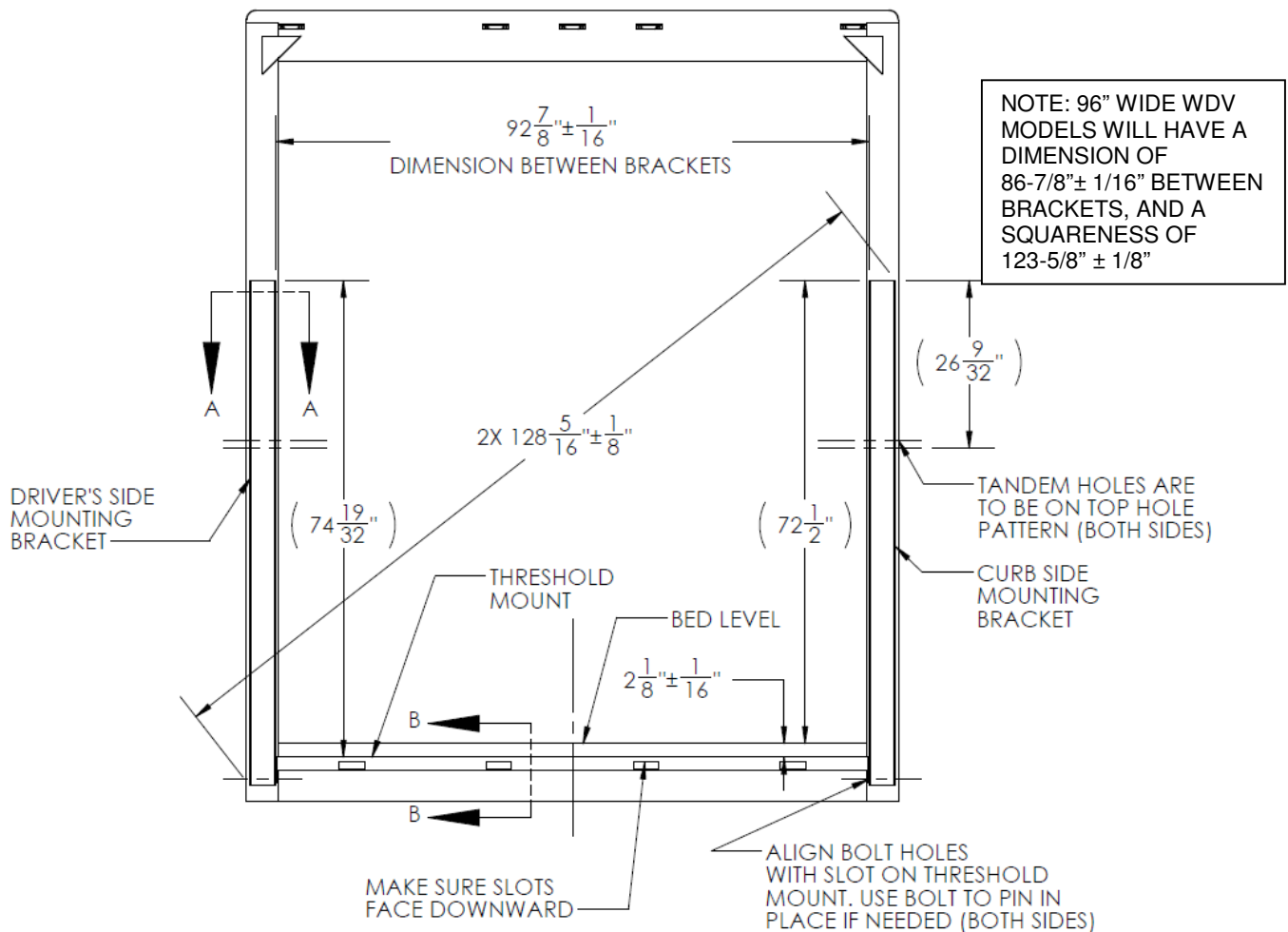

Chapter 3 Basic Mounting Requirements

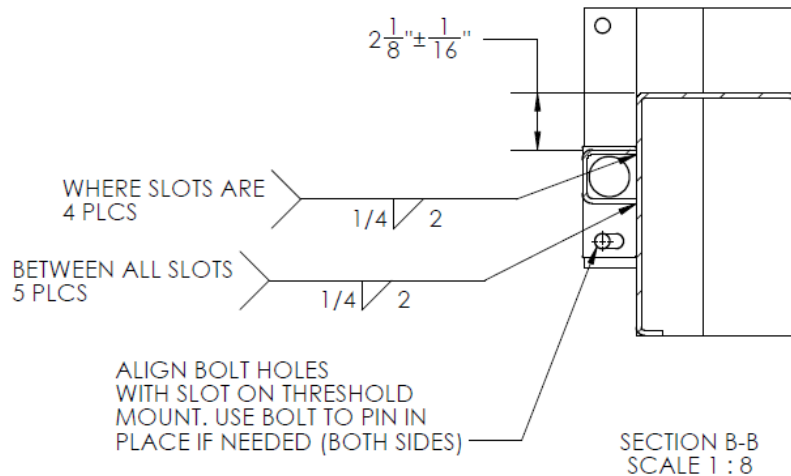
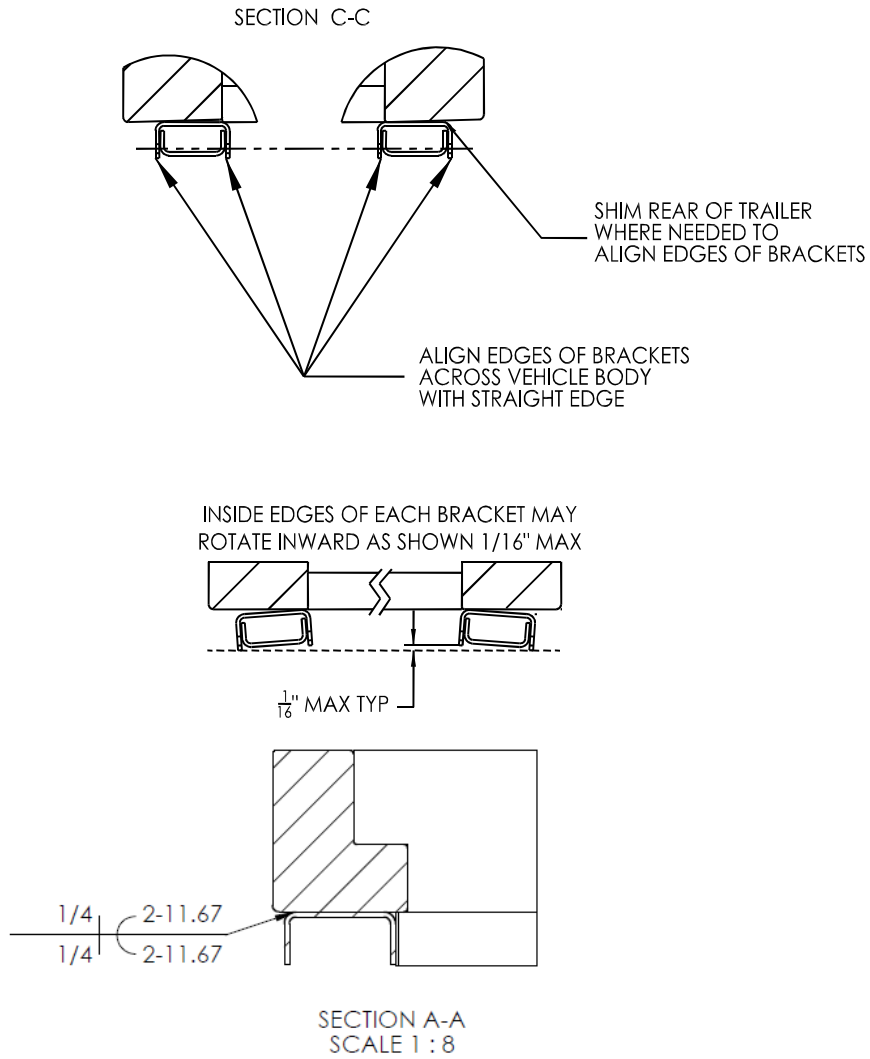

Chapter 3 Basic Mounting Requirements

IF BOLT ON VERTICAL BRACKET EXTENDS INWARD OF DOOR FRAME MORE THAN 1" ADD GUSSETS AS SHOWN BELOW.

GUSSETS NOT PROVIDED

TOP VIEW OF DRIVER'S SIDE REAR CORNER POST

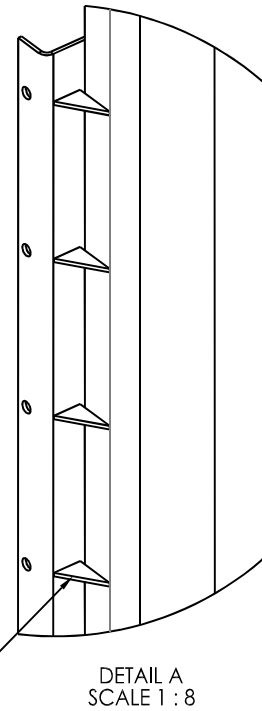
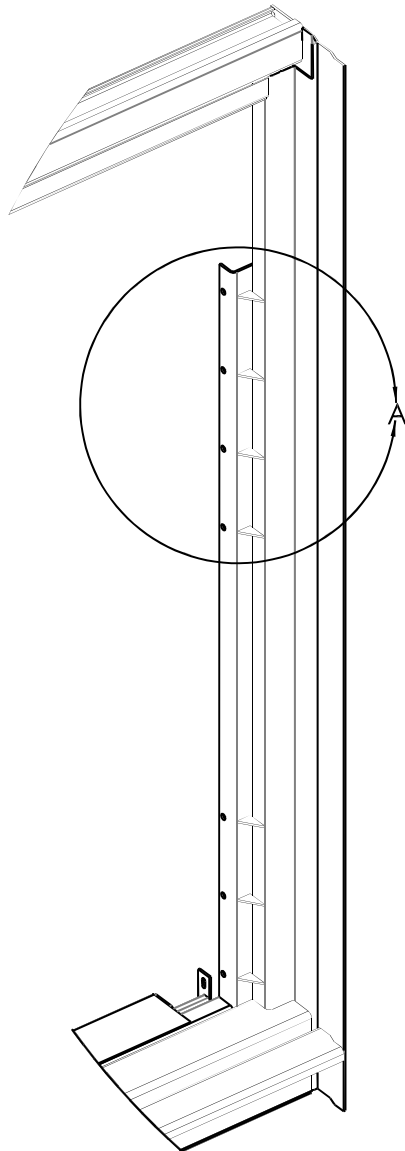
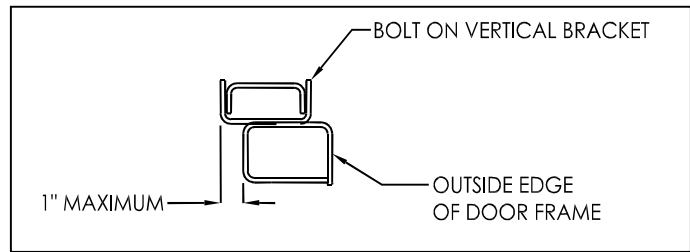

ADD GUSSET CENTERED BEHIND BOLT HOLES (14 PLACES)

GUSSET SHOULD BE 3/16" THICK AND EXTEND TO COVER THE FLAT PORTION OF THE BOLT ON BRACKET THAT EXTENDS INWARD OF THE DOOR FRAME AND THE FLAT PORTION OF THE DOOR FRAME. (AS SHOWN)

Chapter 4 Liftgate Installation

PREPARATION OF BODY

Remove all obstructions that will interfere with Liftgate mounting or operation such as dock bumpers, lights, projections, etc.

Trailer hitches are not to extend beyond the rear body sill or be attached to any part of the Liftgate.

Crossbeam extends down below floor level

Floor

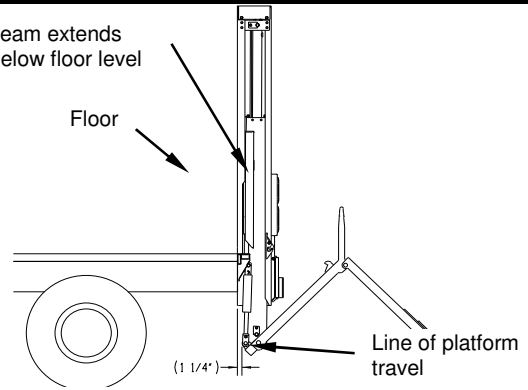

Locate and mark center of vehicle floor and rear sill.

Centerline

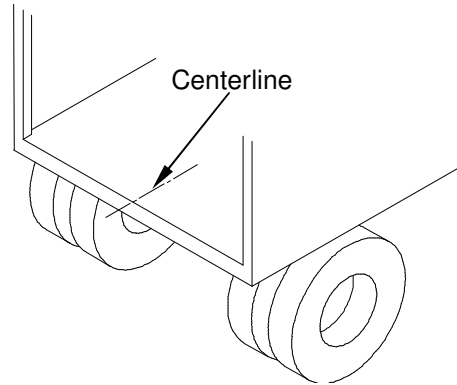

GR01565

On trucks with a short frame (frame does not extend back to rear sill), frame must be extended as shown.

Add channel to vehicle frame & cap so frame extension is flush with rear sill.

Construct a cap from 1/4" x 2" strap or larger to tie sill and frame together.

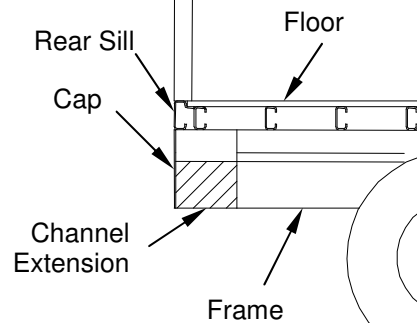

GR01566

If side walls of truck do not meet minimum strength requirements add support straps from corner posts down to side rails as shown.

Locate strap in line with a cross member on side rail

1/4" x 3" bar or heavier material to be used for straps

Reinforce side rail with 1/4" thick steel plate if necessary.

Use 3/16" welds 100% at side rail and corner posts.

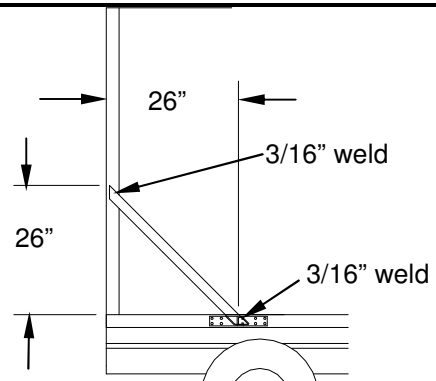

GR02002

Chapter 4 Liftgate Installation

If corner posts are not 90° to the ground, shims will have to be added as shown to compensate for vehicle rake.

NOTICE: Not adding shims may result in the tip of the platform ramp not touching the ground when the liftgate is lowered.

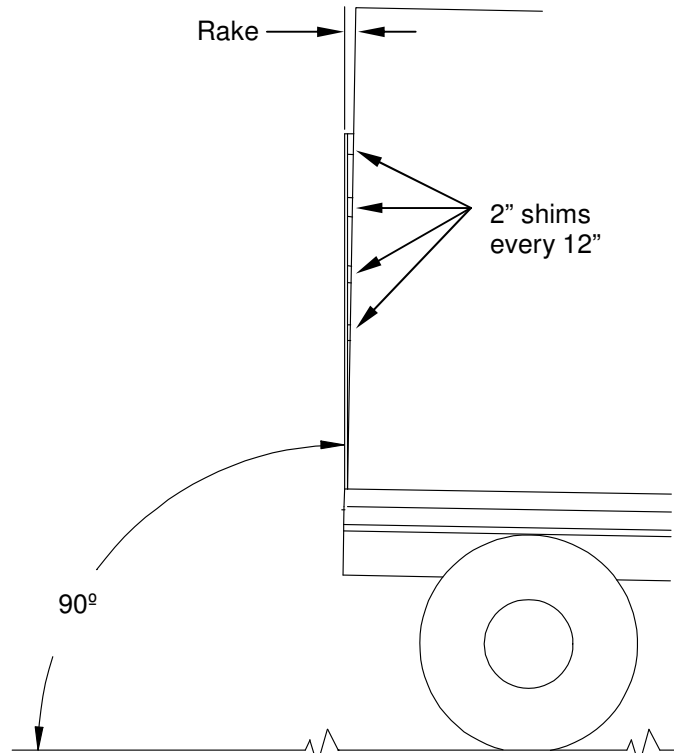

GR00517

PREPARATION OF LIFTGATE

! Remove the Hydraulic/Battery enclosure and any other boxes from the Liftgate. **Support hydraulic enclosure with forklift or suitable heavy lifting device before removing shipping straps. Enclosure may be unbalanced!**

! Do not remove any other shipping straps, supports, or braces from liftgate until instructed to do so.

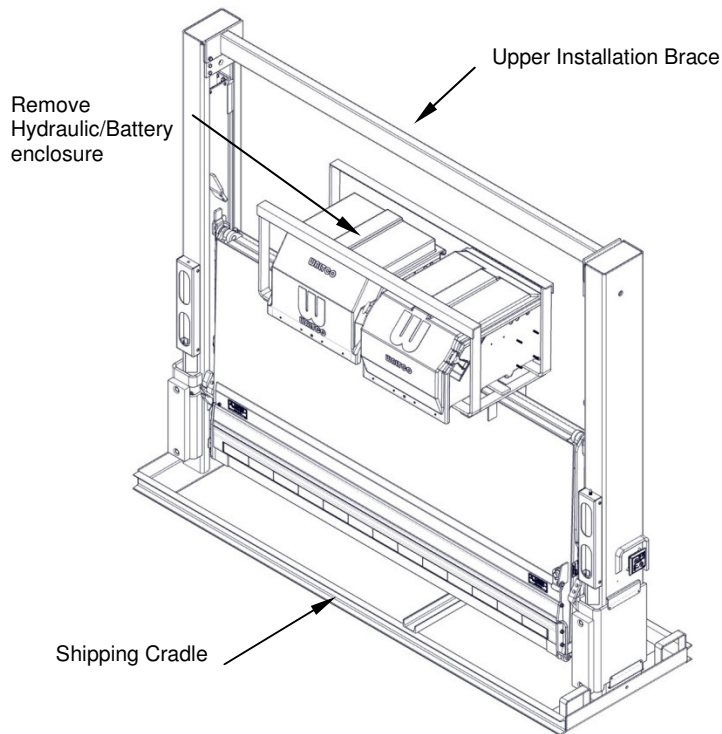

Chapter 4 Liftgate Installation

INSTALLATION OF LIFTGATE

Cut two mounting supports out of angle or channel.

Mounting support should be 6" to 8" long.

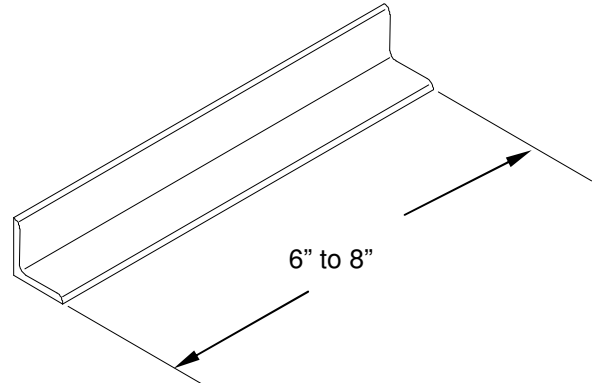

GR01568

Tack weld supports on Sill Extension as shown.

Locate and mark the centerline of Liftgate on top of the Sill Extension.

NOTICE: The columns are **NOT** the same width. **The centerline must be determined as the midpoint between the outside of the columns.**

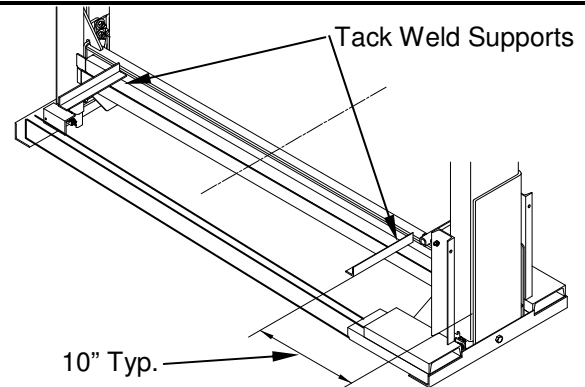

GR02391

Use forklift to raise Liftgate by Installation Brace as shown.

Remove shipping cradle assembly.



Do not remove Installation Fixture Components until Liftgate is fully welded to vehicle.



Do not remove any other components besides the Shipping Cradle.

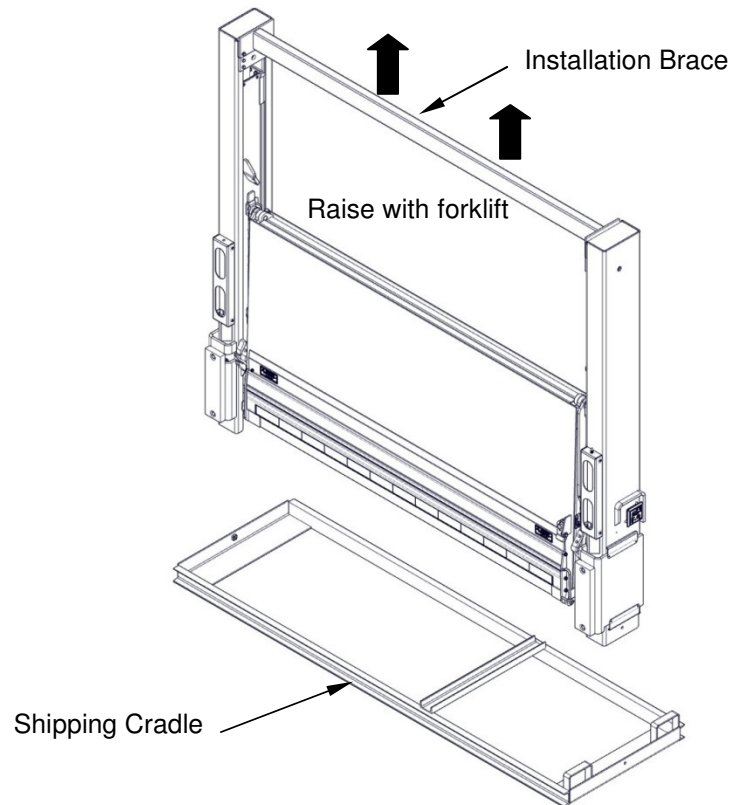

Chapter 4 Liftgate Installation

Use forklift to raise Liftgate by Installation Brace as shown.

Position Liftgate at rear of vehicle so temporary supports rest on the floor of the vehicle and centerline of Liftgate aligns with centerline of vehicle.



STAND CLEAR of installation area while positioning Liftgate.

Lifting Tube

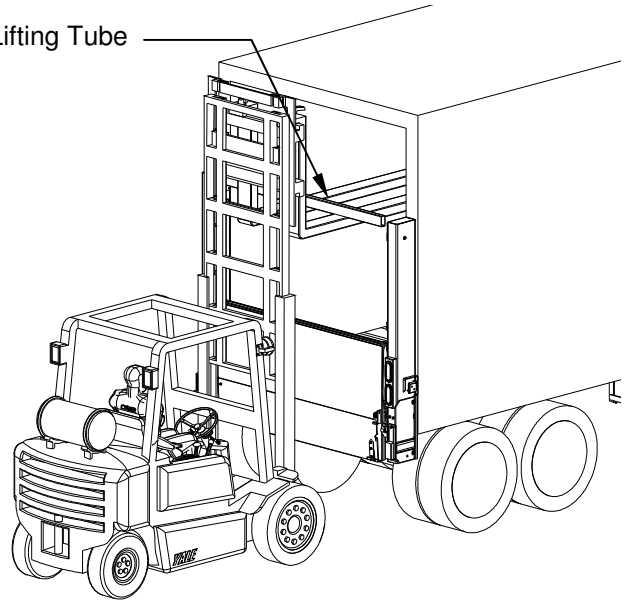

Clamp top of both curb and street side Uprights to the corner posts using large clamps as shown

Street Side Upright shown

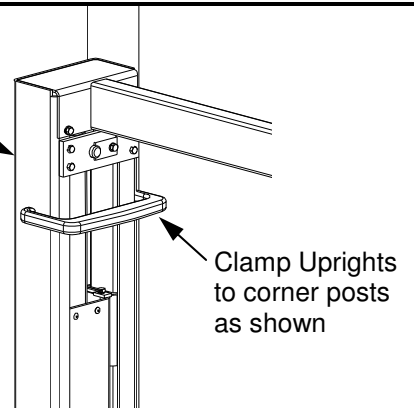

Chapter 4 Liftgate Installation

Squaring liftgate H-Frame on vehicle:

D1 to be within $\pm 1/8$ from D2 minus 1"

D2 minus 1" to be within $\pm 1/8$ from D1

Squareness can be further verified by measuring from corner to corner of H-frame as shown in diagram.

Dimension "D3" is to be within $\pm 1/4$ of "D4" measurement from each corner.

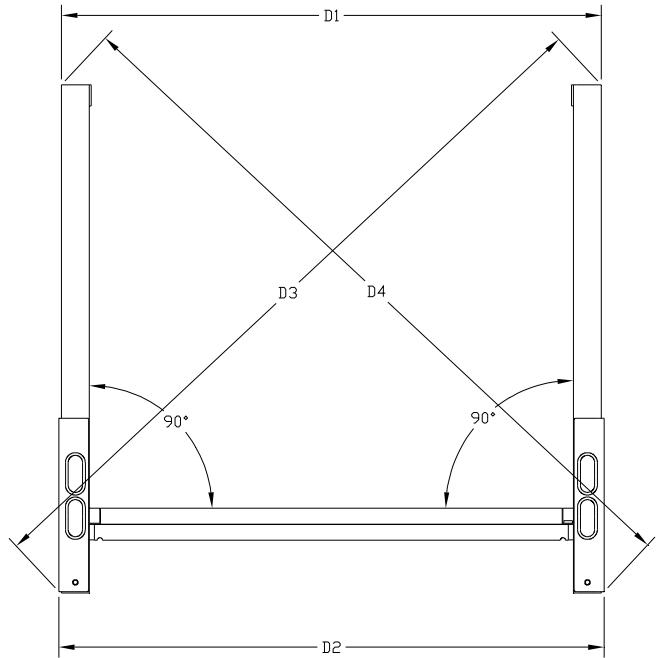

GR02395

Be sure up-rights are square to back of vehicle. Check that they are 90° at the top and bottom of each up-right.

Double check position of Liftgate on the vehicle. Check the following:

- Liftgate is in correct position
- Crossbeam is flush with truck floor
- Liftgate is centered on vehicle
- Upright assemblies are vertical and tight against corner posts
- Uprights are parallel and square to each other.

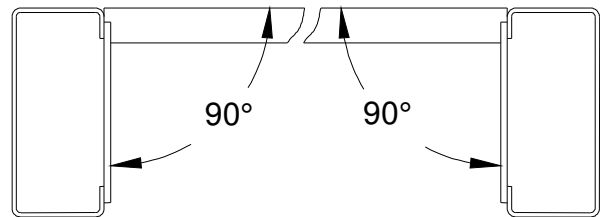

GR01742

Chapter 4 Liftgate Installation

FOR WELD ON GATES:

WELD INSIDE OF COLUMNS FIRST

Weld the inside of the Uprights to the vehicle corner posts with six (6) $\frac{1}{4}$ " x 2" welds equally spaced as shown.

Caution must be taken not to damage closer hoses and wiring in the passenger side Upright.



Excessive heat from welding can cause damage to the hydraulic hoses, slide pads, and wiring harness inside up-rights. Do not weld in area around control switches. Shield all wires and hoses from heat and weld spatter.



When welding, be sure to ground the Welder to the component being welded to prevent potential damage to the hydraulic and electrical systems during welding.

FOR BOLT-ON GATES WITH BRACKETS INSTALLED FROM WALTCO:

Weld inside of bolt-on brackets first in same weld pattern as above.

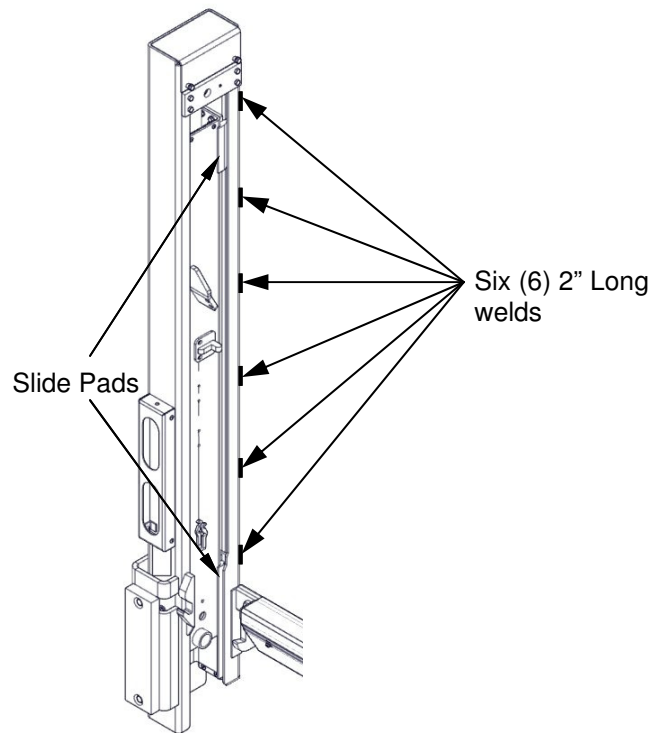
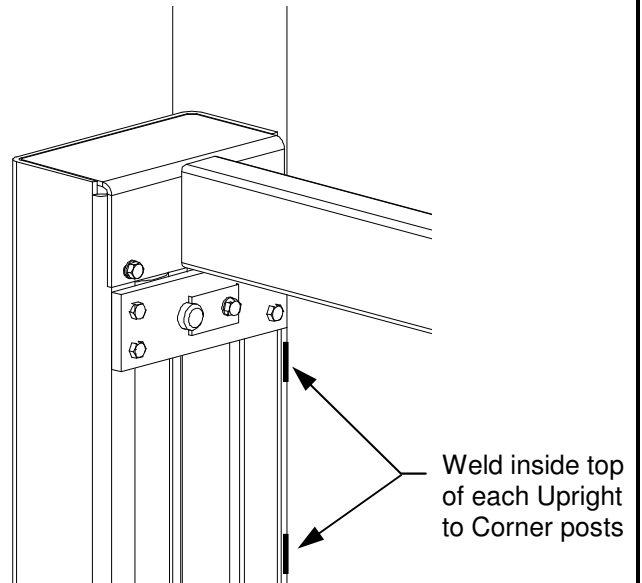

Chapter 4 Liftgate Installation

For Bolt-On gates with Pre-Shipped Bolt-On Brackets:

Insert (1) 1/2-13 X 5" Grade 8 bolt in the bottom hole of the tandem holes on each mount channel. Tighten nut down until there is no more play in the bolt from side to side and nut is snug against channel.

Place gate with forklift down onto the bolts.

Using (16) 1/2-13 x 5" Grade 8 bolts provided, insert bolts through the remaining holes. Add locknuts onto the bolts.

Insert (3) 1/2-13 x 3 Grade 8 bolts into 3 holes in threshold and through slots in housing tube. Run nuts from underneath.

Leave the first bolts in bottom tandem hole as is. Tighten all 1/2" nuts onto grade 8 bolts to 90 ft lbs.

NOTICE:

Head of bolts should be inside the bracket.

Do not torque the bolt head, as the weight of the Liftgate will provide resistance and false torque readings.

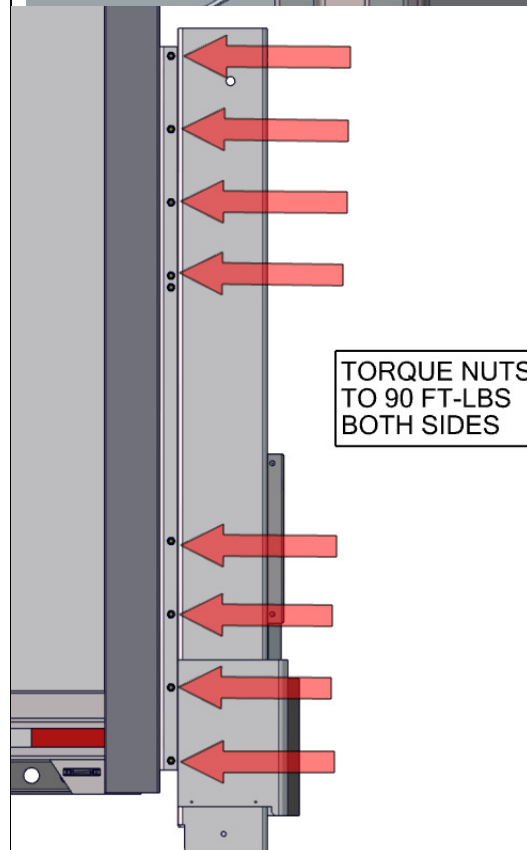
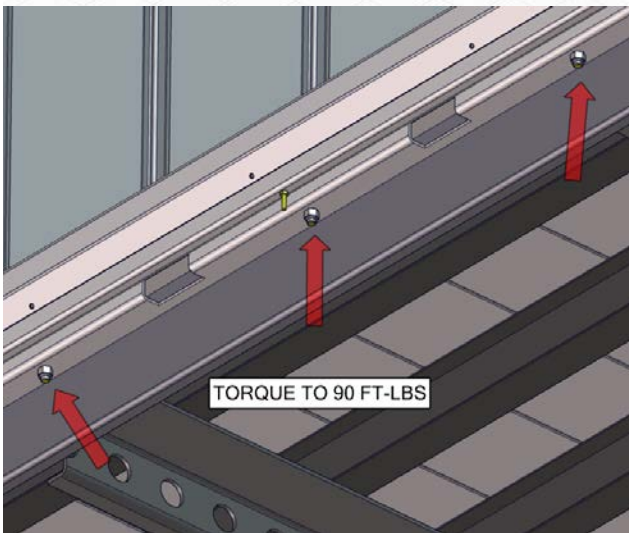
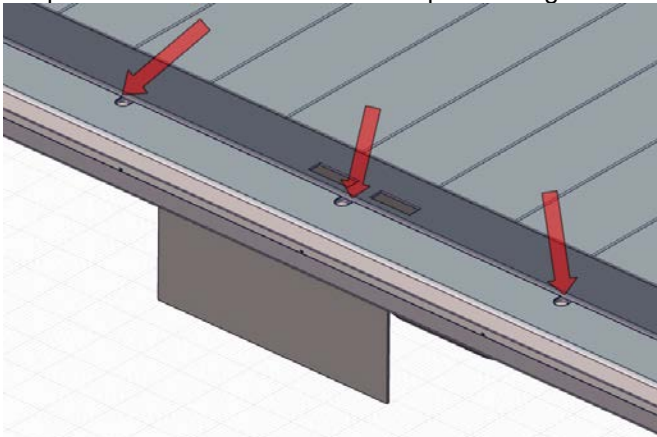
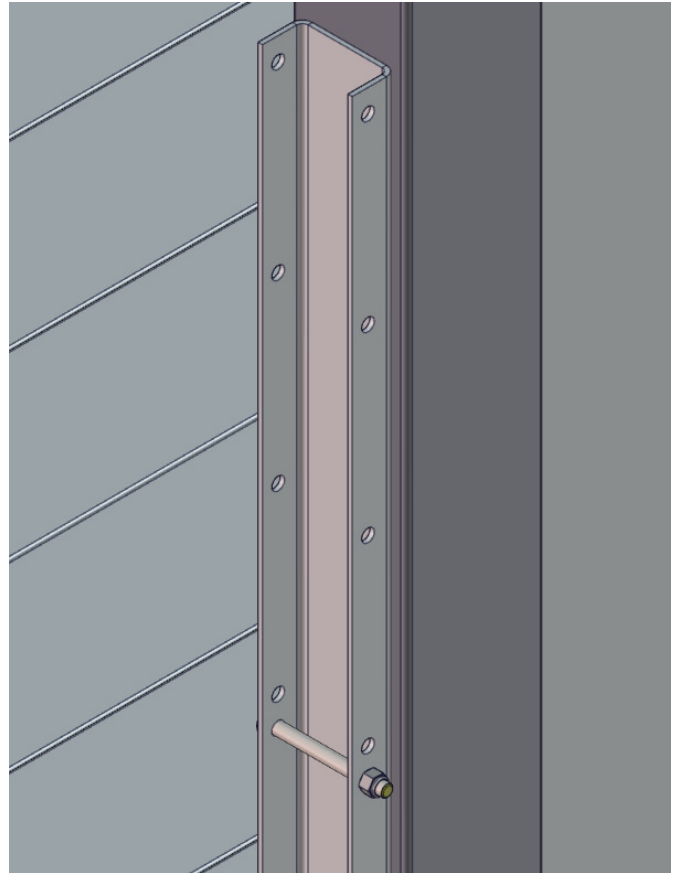

Chapter 4 Liftgate Installation

INSTALLATION OF PUMP & ELECTRIC CONTROLS

Locate a position for hydraulic/battery enclosure. This position should be set for the best use of the length hoses supplied with the Liftgate to avoid having to coil up extra hose length.

In choosing the mounting position, you must ensure that:

- Pump Box cover opens toward curb-side of vehicle.
- Hydraulic Hoses from liftgate reach Pump Box without strain.
- Charge line(s) from front of truck/trailer reaches pumpbox without strain.

For Hydraulic/Battery Enclosure with Battery Box: Weld top channel of hydraulic/battery enclosure to body cross members with a minimum of 1/8" x 12" total welds.

For Hydraulic Enclosure only: Weld top channel of Hydraulic Enclosure to body cross members with a minimum of 1/8" x 6" total weld.

*156" Max for short trailer (28 FT. and under)

**312" Max for long trailer (Over 28 FT.)

Trailer Location

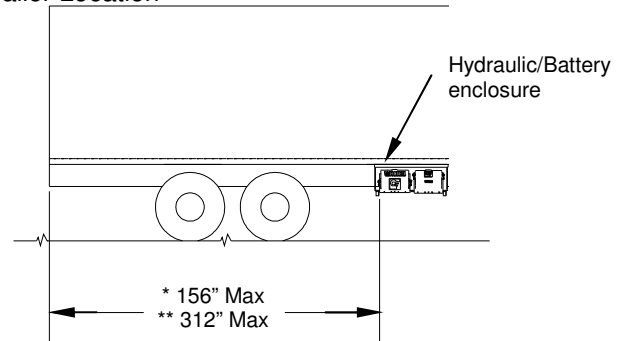

Truck Location

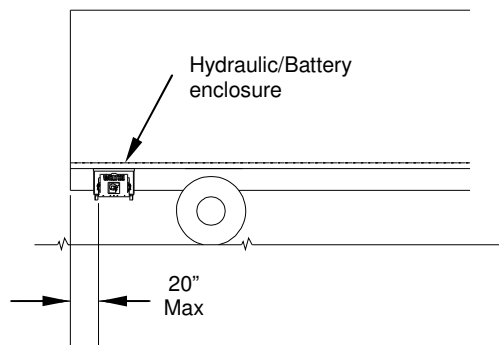

GR10061

Use floor jack or other lifting device to raise Hydraulic/Battery enclosure to vehicle cross members.

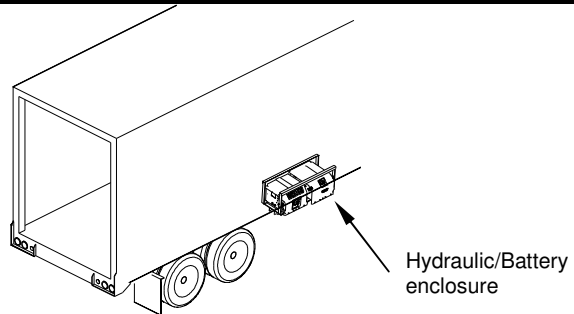

GR10062

Position Braces as shown, so that they butt against vehicle cross members.

For Hydraulic/Battery Enclosure with Battery Box: Weld top channel of hydraulic/battery enclosure to body cross members with a minimum of 1/8" x 12" total welds.

For Hydraulic Enclosure only: Weld top channel of Hydraulic Enclosure to body cross members with a minimum of 1/8" x 6" total weld.



When welding, be sure to ground the Welder to the component being welded to prevent potential damage to the hydraulic and electrical systems during welding.

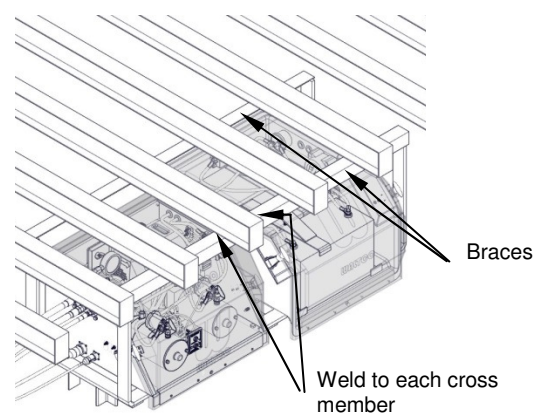

Chapter 4 Liftgate Installation

HYDRAULICS HOSES & LINES

Familiarize yourself with key components using this diagram. Refer back to this diagram as needed during hydraulic hookup.



Keep hydraulic hoses, fittings, and other components free from contamination and debris. Contamination of the Hydraulic System will cause the Liftgate to **operate unevenly** and can lead to **damage of hydraulic components**.

Disconnect the 1/2" hydraulic hoses from each other and connect the line as instructed below.

Note! The 1/4" and 1/2" hydraulic hoses have been connected together to prevent oil from draining from the cylinders and to minimize the amount of bleeding needed when installation is complete.

Connect the 1/2" hydraulic hose with the 1/2" JIC female swivel to the 1/2" JIC male fitting coming out of the pump box. This is the line providing pressure to raise the platform.

Connect the 1/2" hydraulic hose with the 1/2" JIC male swivel to the 1/2" JIC female fitting coming out of the pump box. This is the line providing pressure to lower platform.

Disconnect the 1/4" hydraulic hoses from each other.

Connect the 1/4" hose with the 1/4" JIC female swivel to the 1/4" JIC male fitting coming out of the pump box. This is the line providing pressure to close the platform.

Connect the 1/4" hose with the 1/4" JIC male swivel to the 1/4" JIC female fitting coming out of the pump box. This is the line providing pressure to open the platform.

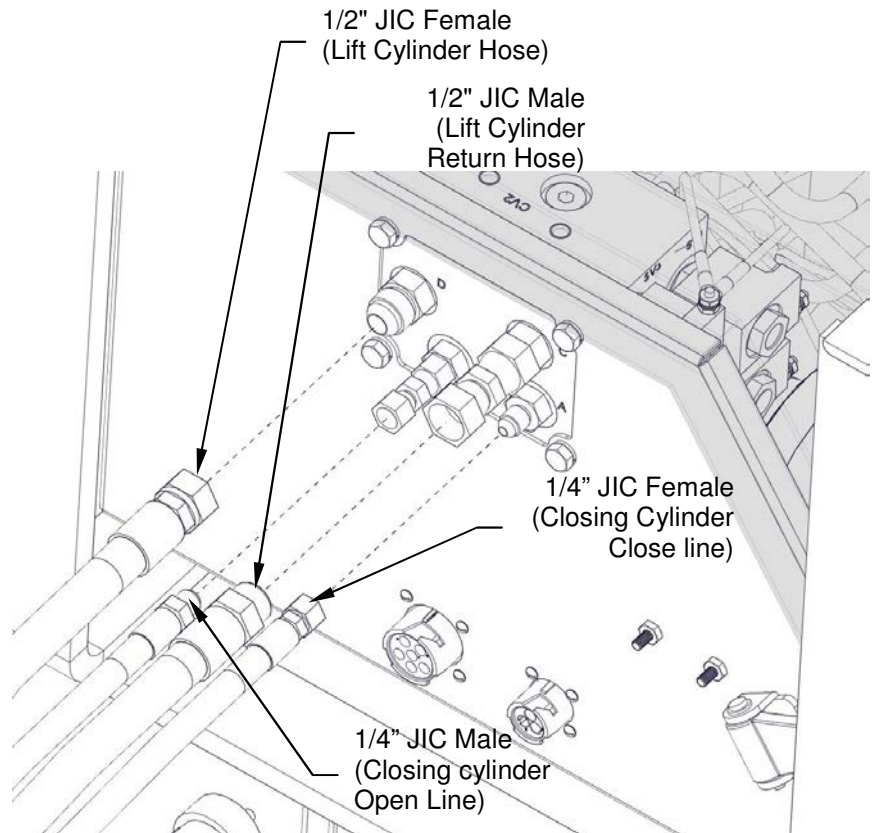

Chapter 4 Liftgate Installation

TRAILER INSTALLATION ONLY

Use the hose guide(s) provide in the trailer installation kits to protect the hoses and wires between liftgate and hydraulic/Battery enclosure.

Hose guide should be positioned so electrical connectors are accessible where they exit the hose guard near rear of trailer.

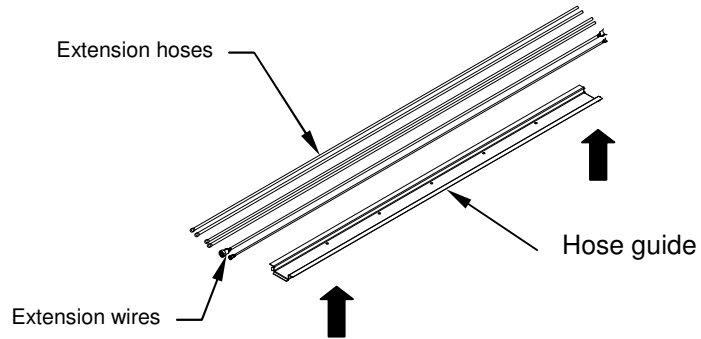

Avoid twisting of hoses.

Avoid sharp bends when routing hoses.

Hoses will contract under pressure. Allow plenty of slack between connecting points.

Do not clamp hoses at bends to allow for length changes when hose is pressurized.

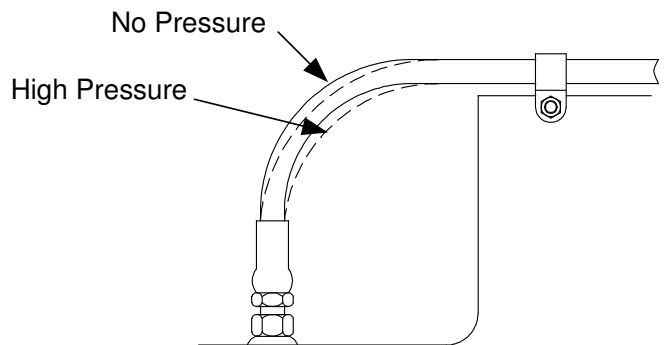

GR00717

Use hose clamps to secure hoses to vehicle.

Note: Hoses must be clamped no less than every 24" to prevent chafing from over the road vibration

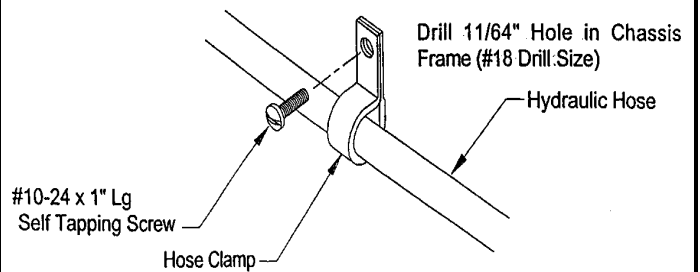

GR00265

Chapter 4 Liftgate Installation

DIELECTRIC GREASE

Add dielectric grease generously to ALL electrical connections.

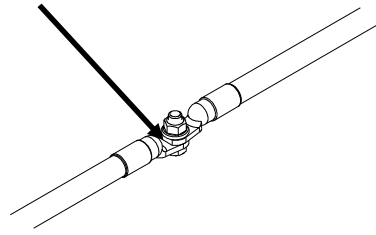

GR02025

BATTERY CABLE CONNECTION

Assure vehicle ignition switch is off and battery ground cables are disconnected at battery.

Refer to installation instructions provided with wiring kit on connecting battery cable(s) and circuit breaker(s).

Two batteries recommended for all WDV Liftgates. Additional batteries connected in parallel may be required for heavy usage.

Secure battery cable to vehicle with cable ties provided.

Original equipment ground cable furnished on vehicle should be at least a number 2 Ga. to insure proper operation of pump unit. An auxiliary ground cable should be added between engine block and vehicle frame if engine is not adequately grounded to vehicle frame.

⚠️ Protect wires from any sharp edges or holes that may abrade insulated covering of wires.

⚠️ Secure battery cable so it does not come near, or in contact with, other vehicle wiring, fuel lines, brake lines, air hoses, exhaust system, etc.

Reconnect battery ground cable(s). DO NOT operate pump unit at this time.

BATTERY SELECTION

WDV55 & 66: Secure a minimum of three Group 31 Dual Purpose, 700 CCA, 180 minute RC (reserve capacity), batteries in battery box with hold-downs provided.

WDV35 & 44: Secure a minimum of two Group 31 Dual Purpose, 700 CCA, 180 minute RC (reserve capacity), batteries in battery box with hold-down provided.

Note: Number of batteries and battery selection can vary by application.

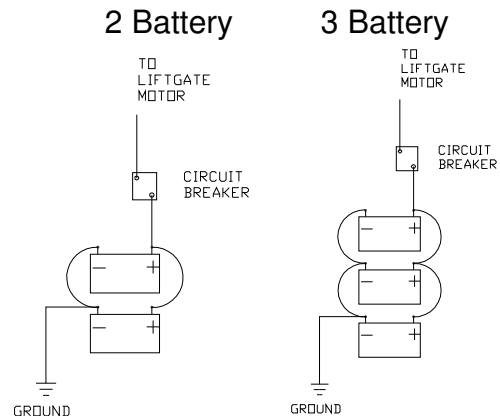

Chapter 4 Liftgate Installation

CHOOSE CHARGING TYPE

Trailer - Dual Pole Socket. (*Preferred for trailers*)

Trailer - Single Pole Socket.

Truck - Direct to starting battery.

Truck - Auxiliary batteries.

Cables supplied will be cut to length as may be required.

DUAL POLE
SOCKET



SINGLE POLE
SOCKET



TRUCK



CHARGE LINE: TRAILER - DUAL POLE SOCKET



- Route #1 charge and #1 ground cable along trailer securing cables every 24". Be certain cables are protected with grommets when passing through metal holes or over sharp edges.
- Attach positive end of #1 charge cable (red) to positive terminal on dual pole socket.
- Attach negative end of #1 ground cable (black) to ground terminal on dual pole socket.
- In liftgate battery box, attach #1 ground cable (black) directly to the negative terminal on the liftgate battery.
- In liftgate battery box, attach #1 charge cable (red) directly to the auto reset circuit breaker terminal.
- Spray bolted connections with insulating varnish.

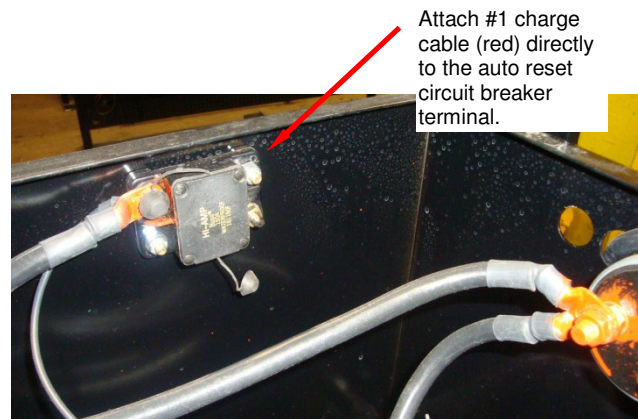

Attach #1 charge cable (red) directly to the auto reset circuit breaker terminal.

Attach #1 charge cable (red) to pos. terminal on back of socket.



Attach #1 ground cable (black) to neg. terminal on back of socket.

Chapter 4 Liftgate Installation

CHARGE LINE: TRAILER - SINGLE POLE SOCKET

Tractor has external ground on plug: (Preferred Single Pole Method)



- a. Route #1 charge and #1 ground cable along trailer securing cables every 24". Be certain cables are protected with grommets when passing through metal holes or over sharp edges..
- b. Attach positive end of #1 charge cable (red) to positive terminal on single pole socket.
- c. Attach negative end of #1 ground cable (black) to a mount bolt on the single pole socket.
- d. In liftgate battery box, attach #1 ground cable (black) directly to the negative terminal on the liftgate battery.
- e. In liftgate battery box, attach #1 charge cable (red) directly to the auto reset circuit breaker terminal.
- f. Spray bolted connections with insulating varnish.



Attach #1 charge cable (red) directly to the auto reset circuit breaker terminal.

Attach #1 charge cable (red) to terminal on back of socket.



Attach #1 ground cable (black) to mount bolt.

Additional grounding needed for single pole connector without external ground cable: (Make sure Fifth Wheel is grounded to tractor batteries)



- g. Drill 3/8" hole in fifth wheel plate as shown (Approx. 4" in from side rail.) grind or sand area around hole to bare steel. Make sure hole location will not interfere with movement of the fifth wheel.
- h. Run #1 ground cable to fifth wheel plate and bolt in place. Be certain to clean corrosion from fifth wheel plate before bolting.
- i. Make a cable using excess ground cable, run another ground cable from fifth wheel plate ground bolt to a mount bolt on the single pole socket.
- j. Spray bolted connections with insulating varnish after bolting.



Bolted to Fifth Wheel plate

Chapter 4 Liftgate Installation

TRUCK: Liftgate running off vehicle batteries only:

- a. In liftgate battery box, attach #1 ground cable (black) directly to the power unit valve manifold with 1/4" bolt.
- b. In liftgate battery box, attach #1 power cable (red) directly to the master disconnect switch.
- c. Route #1 power cable and #1 ground cable along truck chassis securing them every 24". Be certain cables are protected with grommets when passing through metal holes or over sharp edges.
- d. Mount the 150A circuit breaker in the truck battery box.
- e. Attach positive end of #1 power cable to AUX terminal on 150A circuit breaker.
- f. Attach a #1 jumper cable from the positive battery terminal to BAT terminal on 150A circuit breaker.
- g. Attach negative end of #1 ground cable to ground terminal on truck starting battery.
- h. Spray bolted connections with insulating varnish.

Hydraulic/Battery Enclosure

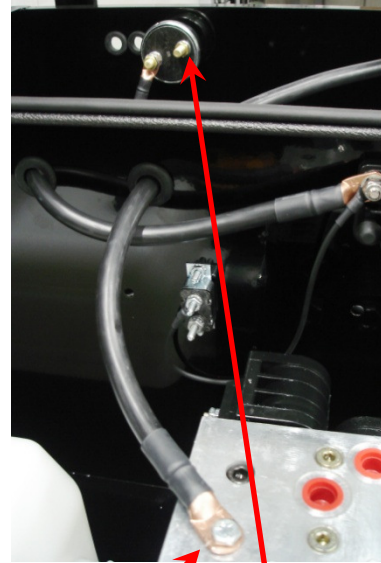

Ground to valve manifold.

Red charge line to this terminal.

TRUCK: Liftgate running off auxiliary batteries:

- a. In liftgate battery box, attach #1 ground cable (black) directly to the negative terminal on the liftgate battery.
- b. In liftgate battery box, attach #1 charge cable (red) directly to the auto reset circuit breaker terminal.
- c. Route #1 power cable and #1 ground cable along truck chassis securing them every 24". Be certain cables are protected with grommets when passing through metal holes or over sharp edges.
- d. In truck starting battery box, mount the 150A auto reset circuit breaker.
- e. In truck starting battery box, attach positive end of #1 charge cable (red) to AUX terminal on 150A circuit breaker.
- f. In truck starting battery box, attach a #1 jumper cable from the positive battery terminal to BAT terminal on 150A circuit breaker.
- g. In truck starting battery box, attach negative end of #1 ground cable (black) to ground terminal on truck starting battery.
- h. Spray bolted connections with insulating varnish.

Hydraulic/Battery Enclosure

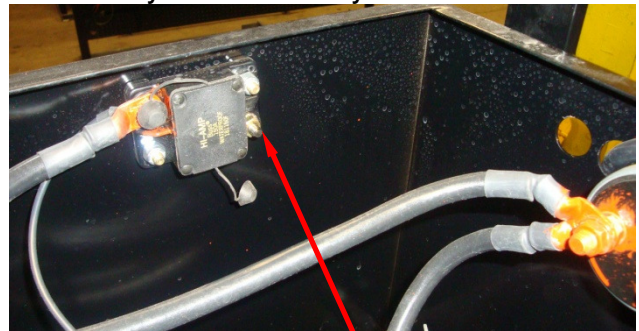

Attach #1 charge cable (red) directly to the auto reset circuit breaker terminal.

Chapter 4 Liftgate Installation

FINISH WELDING THE LIFTGATE TO THE VEHICLE

Weld the outside of the Uprights to the vehicle corner posts with eight (8) 1/4" x 2" minimum welds equally spaced as shown.



Excessive heat from welding can cause damage to the hydraulic hoses, slide pads, and wiring harness inside up-rights. Do not weld in area around control switches. Shield all wires and hoses from heat and weld spatter.

NOTICE:

When welding, be sure to ground the Welder to the component being welded to prevent potential damage to the hydraulic and electrical systems during welding.

FOR BOLT-ON GATES WITH BRACKETS INSTALLED FROM WALTCO:

Weld outside of bolt-on brackets using same pattern.

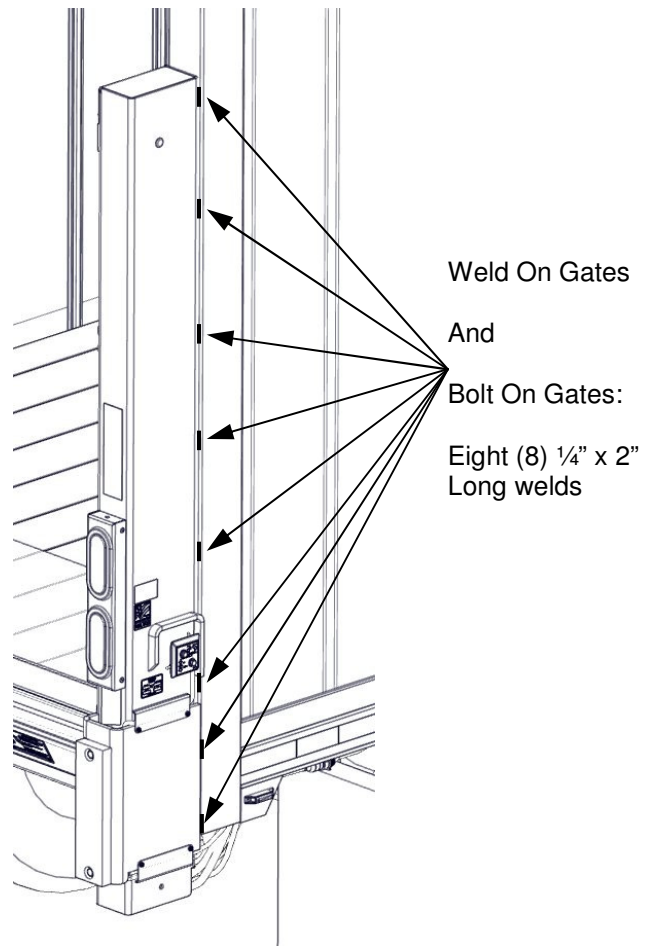

Chapter 4 Liftgate Installation

Remove all remaining Installation Fixture Components

Remove upper Installation Brace.

IMPORTANT:

Be certain Upright caps are secured in place using installation brace bolts.

Remove upper Installation Brace.

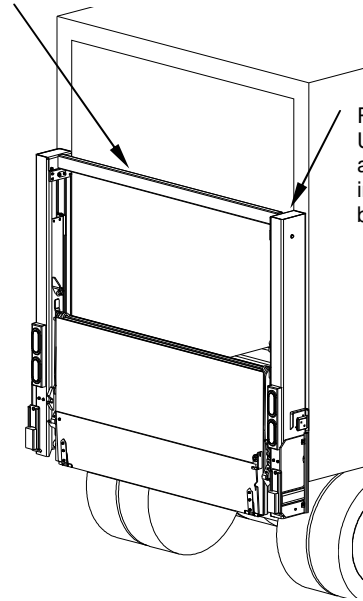

Replace Upright caps after removing installation brace

FOR WELD ON GATES:

Weld the Crossbeam of the Liftgate to the vehicle sill with five (5) $\frac{1}{4}$ " x 2" long welds as shown.



Excessive heat from welding can cause damage to the hydraulic hoses and wiring harness inside up-rights. Do not weld in area around control switches. Shield all wires and hoses from heat and weld spatter.



When welding, be sure to ground the Welder to the component being welded to prevent potential damage to the hydraulic and electrical systems during welding.

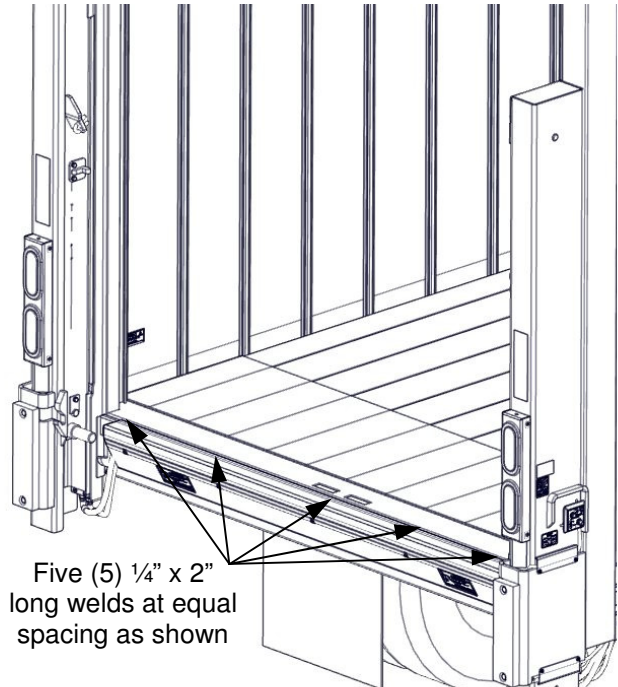

Five (5) $\frac{1}{4}$ " x 2" long welds at equal spacing as shown

Chapter 4 Liftgate Installation

FOR BOLT-ON GATES WITH BRACKETS ATTACHED FROM WALTCO:

Weld the Crossbeam Bracket of the Liftgate to the vehicle sill with nine (9) 1/4" x 2" long welds as shown. Weld inside slots and between slots as shown.



Excessive heat from welding can cause damage to the hydraulic hoses and wiring harness inside uprights. Do not weld in area around control switches. Shield all wires and hoses from heat and weld spatter.



When welding, be sure to ground the Welder to the component being welded to prevent potential damage to the hydraulic and electrical systems during welding.

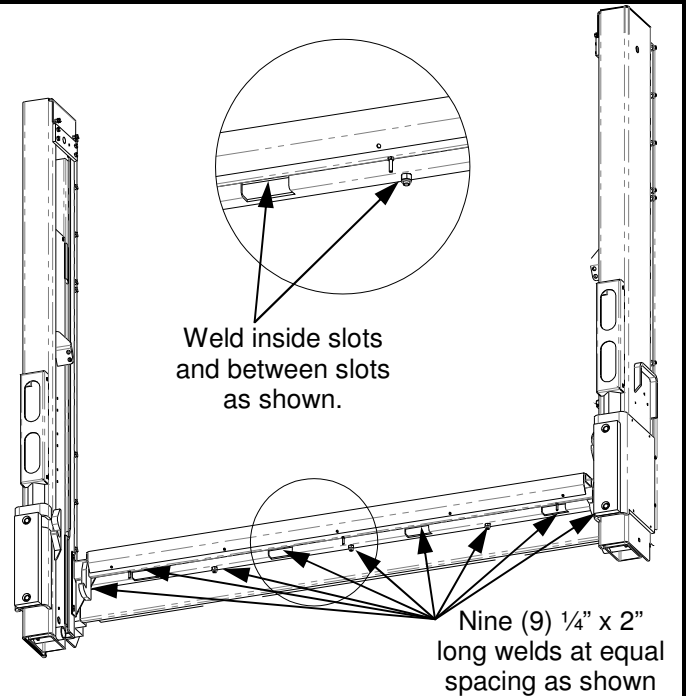

Weld inside slots and between slots as shown.

Nine (9) 1/4" x 2" long welds at equal spacing as shown

FILLING HYDRAULIC RESERVOIR

For Gravity Down Gates:

Lower platform to the ground in the open position.

For Gravity Down with Power Down Option:

Raise platform up to bed level in the open position.

The pump reservoir is pre-filled by Waltco at the factory. Check oil level in hydraulic reservoir. Add oil, if required, to fill it to within 2" of top of reservoir. Do not fill to top.

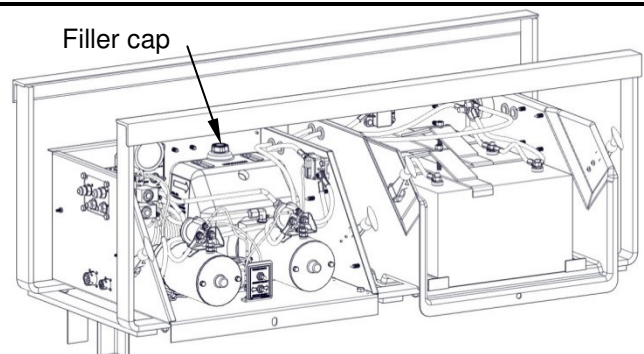

Recommended Fluids	
Temperature Range	Acceptable Fluids
0° to 120° F	Waltco Biodegradable Liftlube™ part #85803860
	Shell Tellus S2 V 32
	Chevron Rando HDZ 32
-20° to 90° F	Waltco Biodegradable LiftLube Arctic part #85803866
	Waltco All Season Hyd Oil Part 85803867
	Shell Tellus S2 V 15
	Mobil DTE 10 Excell 15
	Chevron Rando HDZ 15

A good quality SAE 10W motor oil may also be used in temperatures above 32° F.

Fill reservoir

- Fill with recommended fluid or equivalent.
- Fill the reservoir to within 2" from the top. (Filling instructions above)
- Fluids are available from the Waltco parts Dept. 1-800-411-5685 www.waltco.com

NOTE:

Do not use the following fluids:

- Brake Fluid**
- Power steering fluid**
- Automatic Transmission Fluid (ATF)**

Chapter 4 Liftgate Installation

CHECK TRAVEL LATCH ENGAGEMENT

Store platform in travel latch.

Check that travel ear engages the cam by 3/8" minimum.

If travel ear engages cam less than 3/8" add retaining ring to drivers side hinge pin between platform and runner hinge tube. See INSTALLING PLATFORM SHIM instructions below.

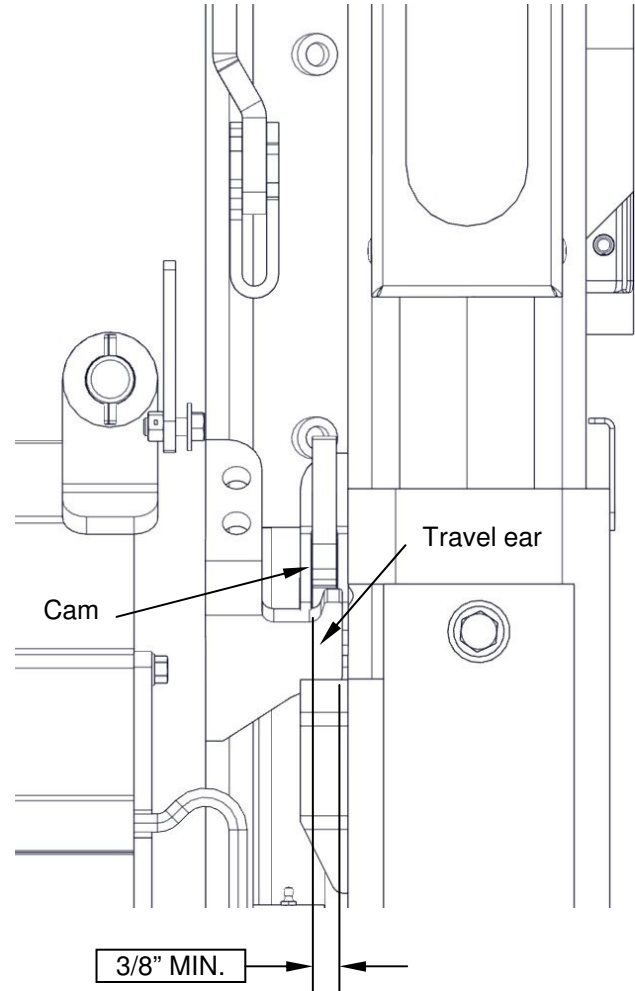

Chapter 4 Liftgate Installation

INSTALLING PLATFORM RETAINING RING

- a. Retaining rings should be zip tied to one of the hydraulic hoses inside the pumpbox. Two are included if necessary.
- b. Lower platform to 20" above ground.
- c. Push platform towards passenger side to make room for retaining ring.
- d. Insert retaining ring between platform and runner hinge tube by snapping onto platform hinge pin.
- e. If travel ear engagement distance is still less than 3/8" add second retaining ring if platform can be moved towards curb side to make a gap greater than 1/8".;

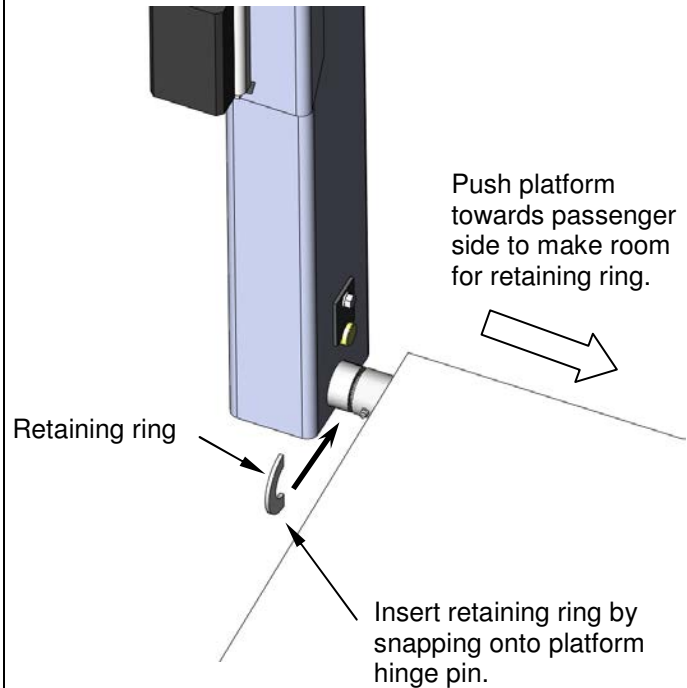

BLEEDING THE LIFTING CYLINDERS

- f. Run the power unit until the platform is stopped at its maximum lifting height. Note: Master disconnect located in pump box must be on to run liftgate.
- g. With the platform at the maximum lifting height continue to run the power unit for 35 seconds.
- h. Let the power unit rest for 5 minutes (or switch to auxiliary pump) and run power unit for 35 seconds again with the platform at the maximum lifting height.
- i. The lifting cylinders are now bled.

Chapter 4 Liftgate Installation

BLEEDING THE CLOSING CYLINDER

- a. Open Platform.
- b. Lower Platform to the ground.
- c. Remove retainer from platform cylinder pin.
- d. Retract POC cylinder using switch.
- e. Remove hose from upper fitting of POC cylinder.
- f. Run fluid through hose by operating switch as if trying to close platform. Note: Stop when fluid exiting the hose is running clear.
- g. Reattach hose to upper fitting of POC cylinder.
- h. Extend POC cylinder using switch.
- i. Remove hose from lower fitting of POC cylinder.
- j. Run fluid through hose by operating switch as if trying to open platform.
Note: Stop when fluid exiting the hose is running clear.
- k. Reattach hose to lower fitting of POC cylinder.
- l. Align POC cylinder clevis with bracket on platform.
- m. Replace the platform cylinder pin and retainer.

Chapter 4 Liftgate Installation

POWER UNIT HYDRAULIC/ELECTRICAL SCHEMATIC - SINGLE POWER UNIT – POWER DOWN

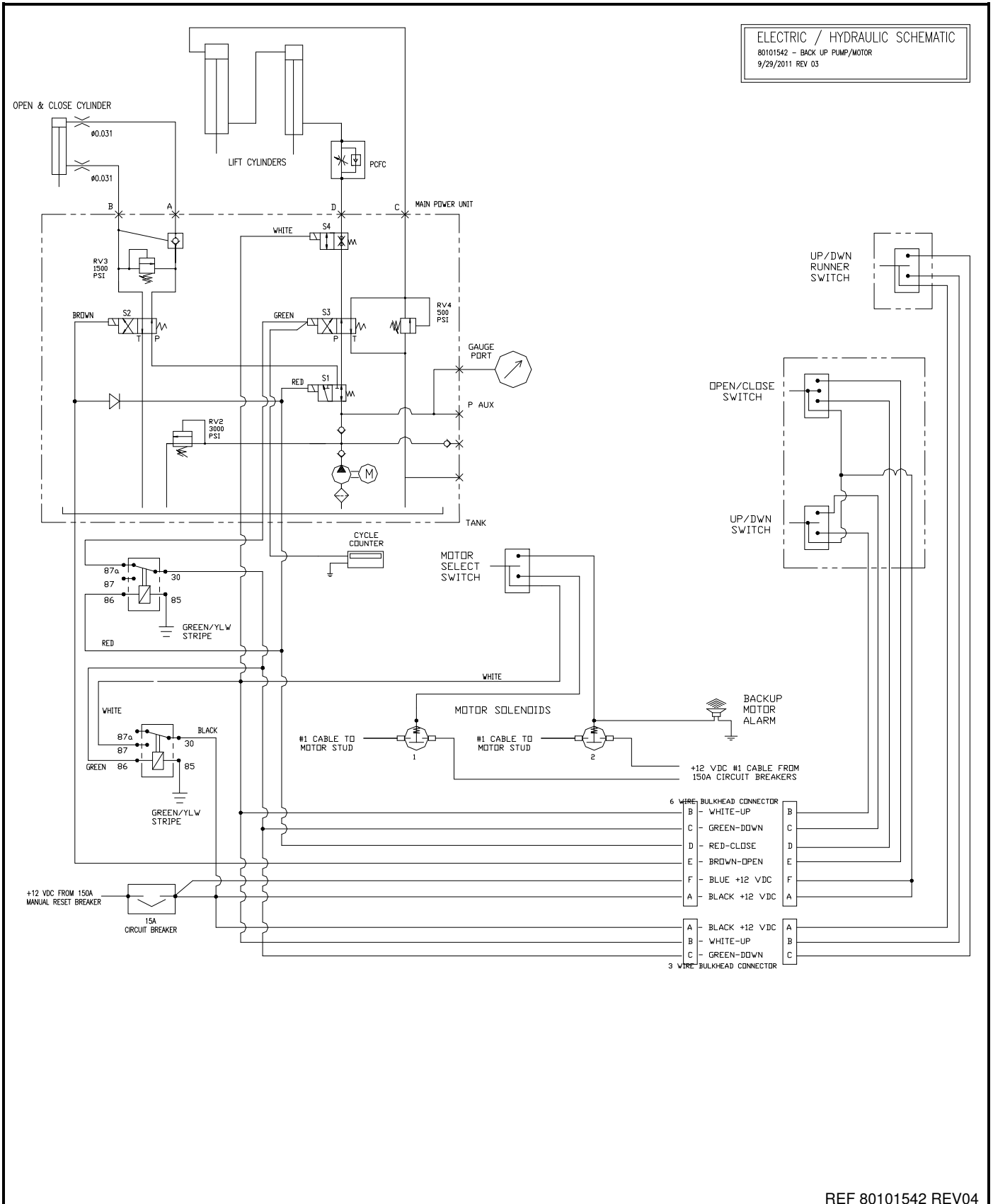

Chapter 4 Liftgate Installation

POWER UNIT HYDRAULIC/ELECTRICAL SCHEMATIC - SINGLE POWER UNIT – GRAVITY DOWN ON DEMAND

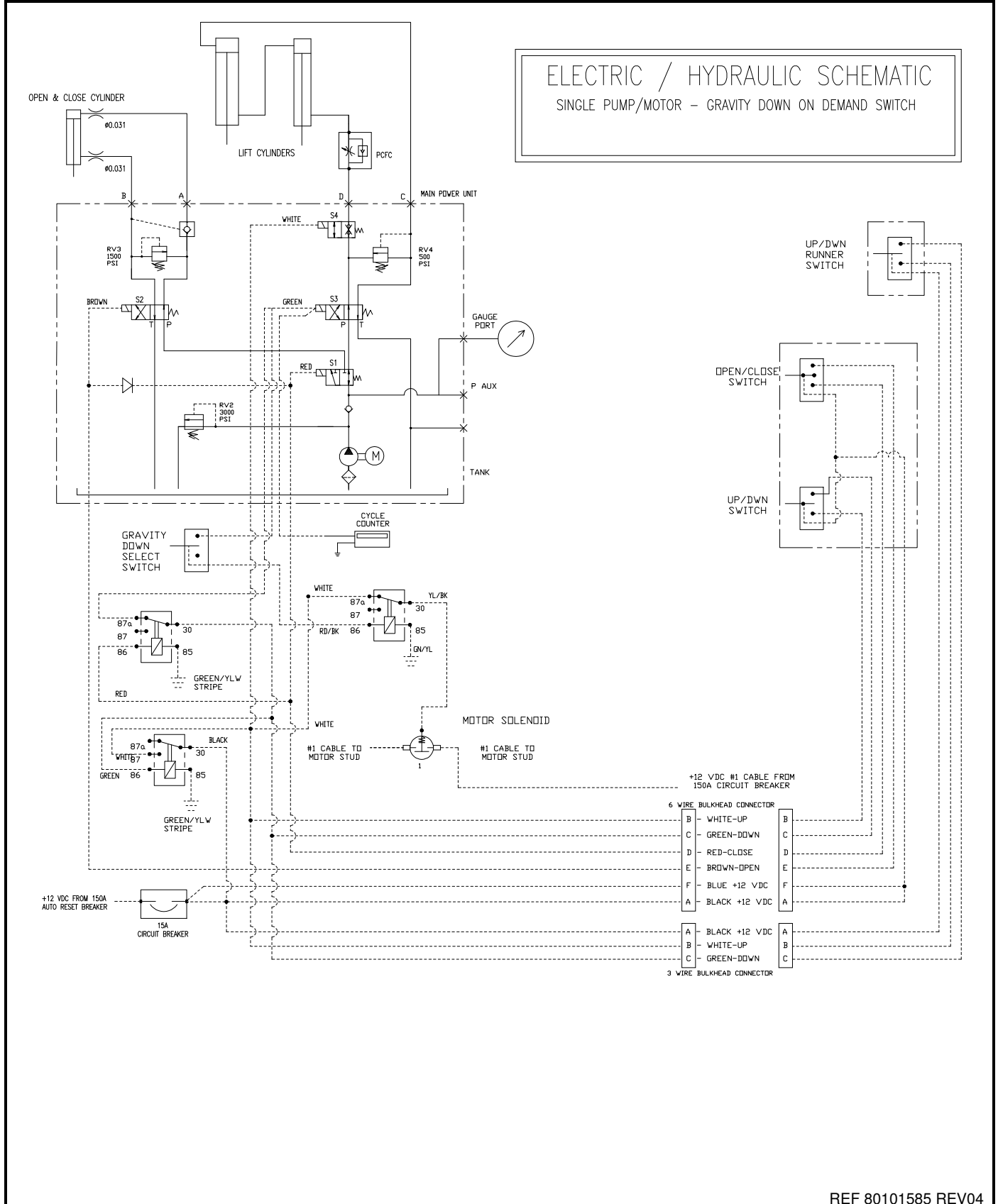

REF 80101585 REV04

Chapter 4 Liftgate Installation

POWER UNIT HYDRAULIC/ELECTRICAL SCHEMATIC - DUAL PUMP MOTOR WITH BACKUP/AUXILLARY - POWER DOWN

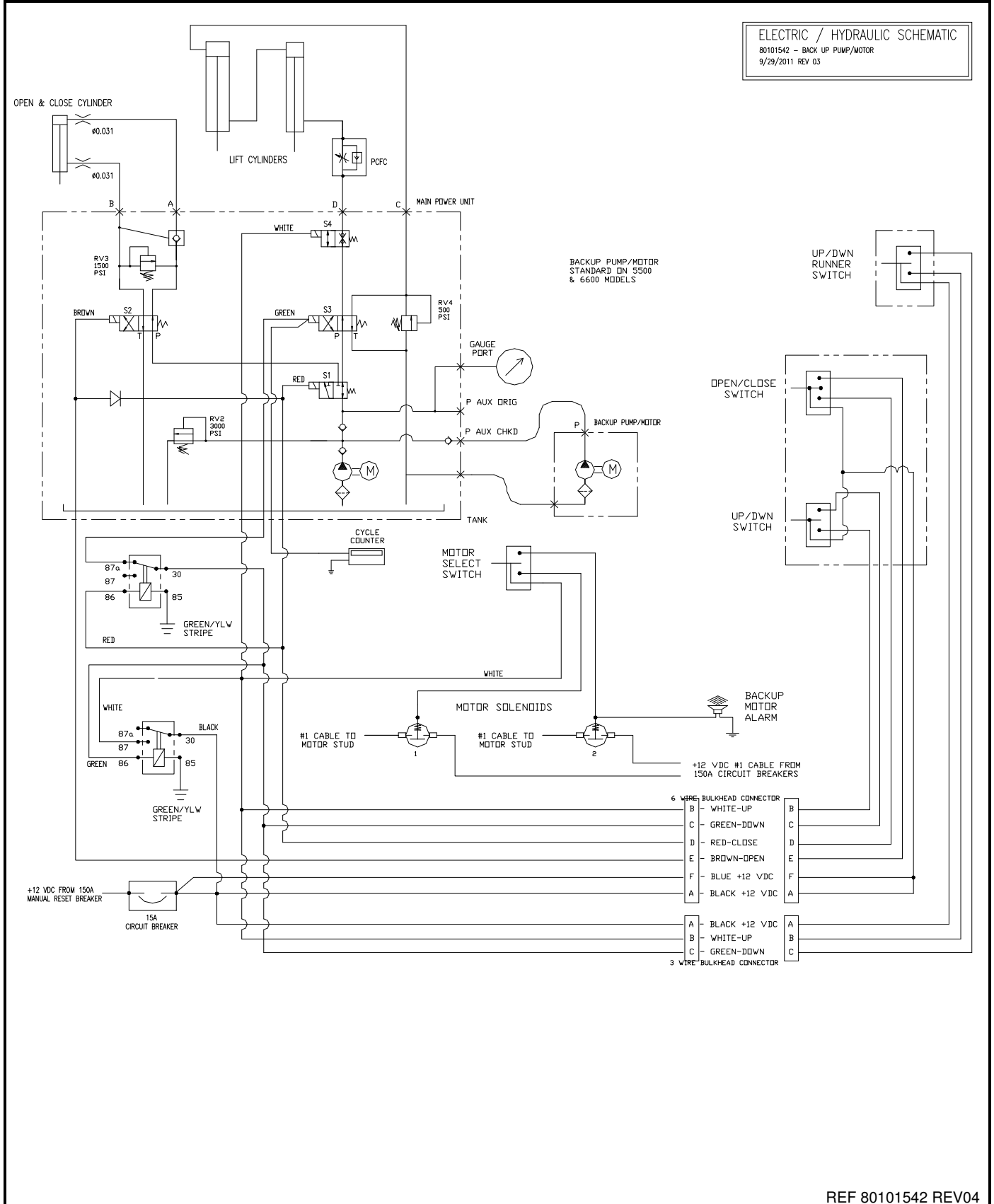

REF 80101542 REV04

Chapter 4 Liftgate Installation

POWER UNIT HYDRAULIC/ELECTRICAL SCHEMATIC - DUAL PUMP MOTOR WITH BACKUP/AUXILLARY - GRAVITY DOWN ON DEMAND

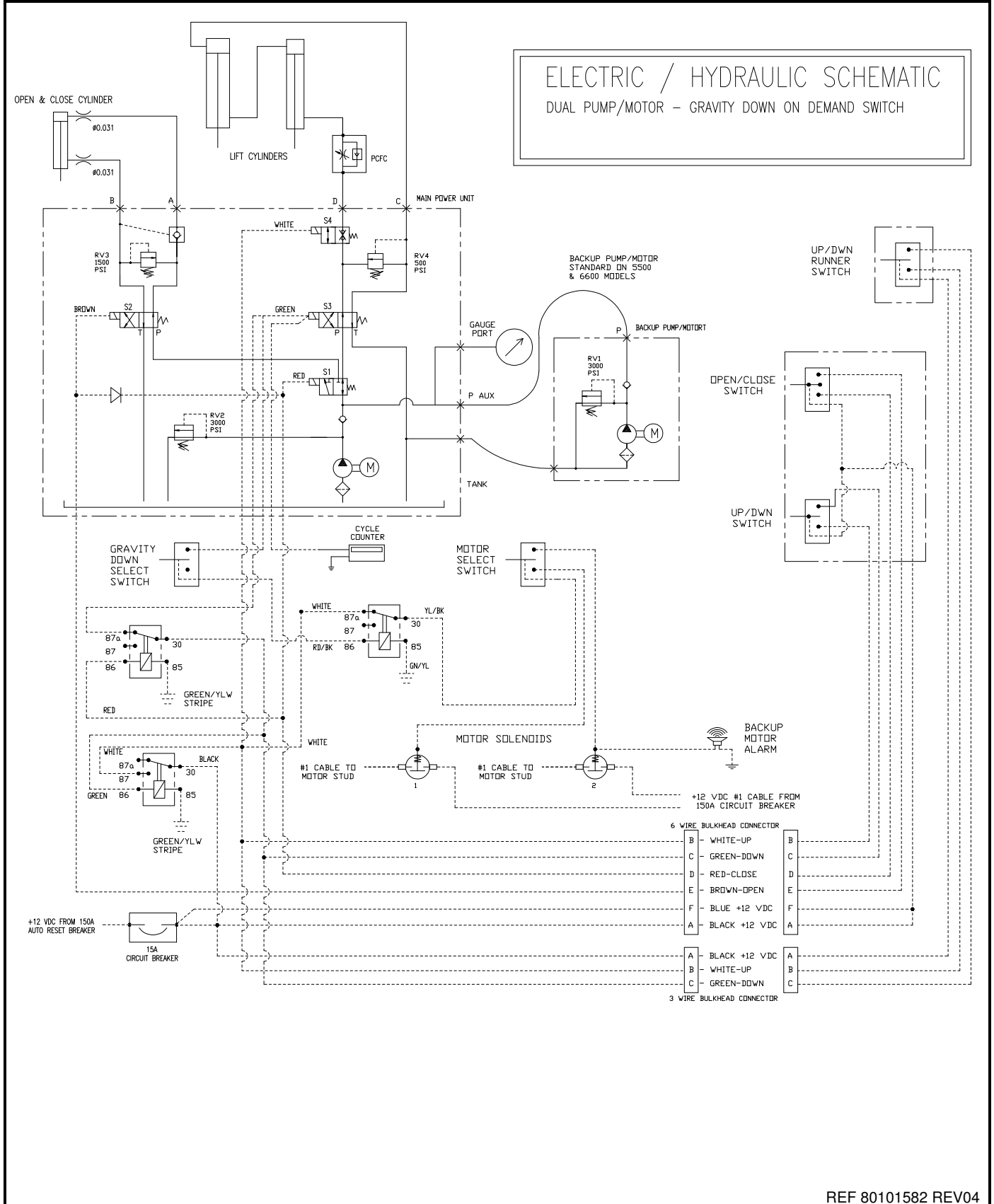

REF 80101582 REV04

Chapter 4 Liftgate Installation

TRUCK AND TRAILER LIGHT SCHEMATICS

Standard harness comes with AMP Superseal 1.5 series connector that plugs directly into many O.E.M. light harnesses. Adapters are available for different harness connectors.

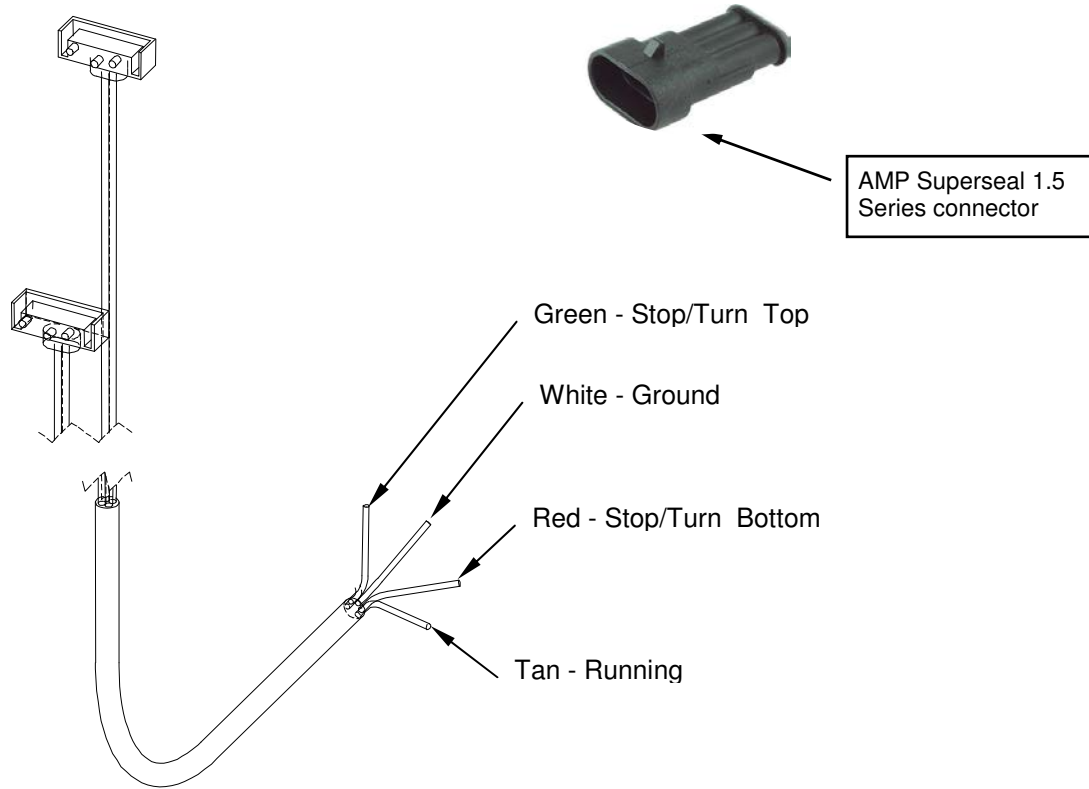

GR01666

Chapter 4 Liftgate Installation

CHECK OPERATION OF LIFTGATE

Check that all controls operate correctly per following instructions. Check both Inside Raise/Lower switches and Outside column switches as follows.



Do not allow anyone to stand in, or near area in which platform will open and lower.

Check that Liftgate operates freely and smoothly through operational cycle without unusual noise or vibration.

Check that platform opens in 7 to 9 seconds and closes in 8 to 10 seconds.

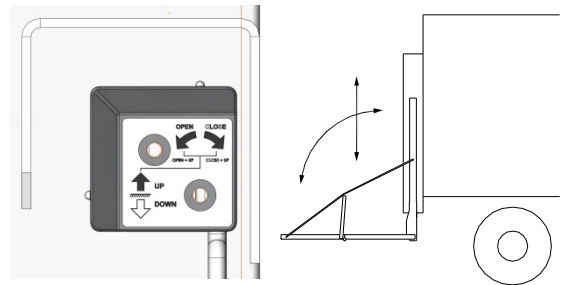

GR02034

OPENING PLATFORM FROM STORED POSITION

1. Turn on power to liftgate by turning the master disconnect switch, located on pump box, to the "ON" position.
2. Be certain operating area around platform is clear before opening platform.
3. Using the "UP" toggle switch, power platform up so that it is completely out of the travel locks.

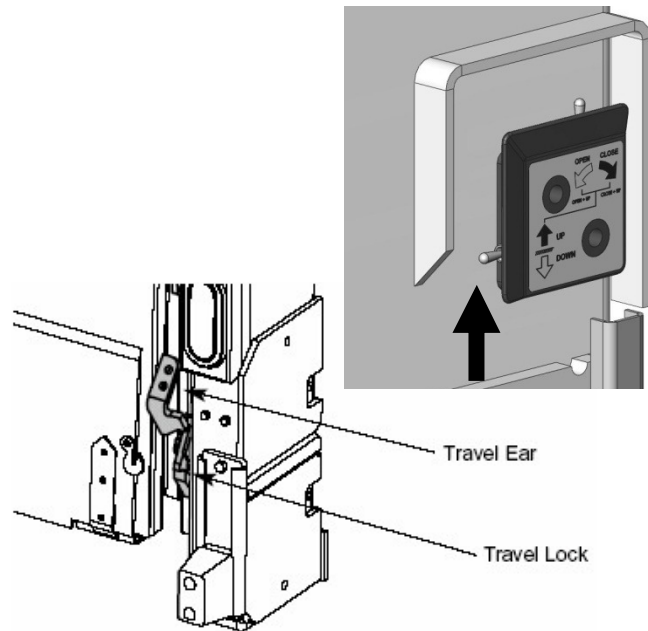

OPENING PLATFORM FOR LOADING

1. Raise the platform until travel stops. (Fully raised)
2. Using the "UP" toggle switch and "OPEN" toggle switch simultaneously, power open platform.
3. Using the "DOWN" toggle switch, lower platform for use.

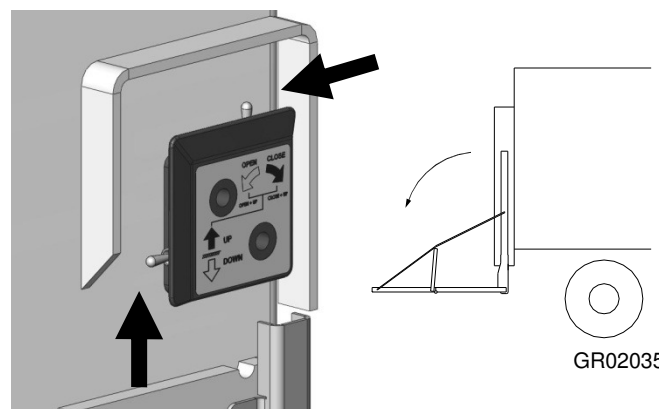

GR02035

Chapter 4 Liftgate Installation

RAISING AND LOWERING PLATFORM

Using the “DOWN” toggle switch, lower platform for use.

Use the “UP” toggle switch to raise platform.



Ensure platform and flip ramp are fully lowered when loading and unloading platform at ground level.

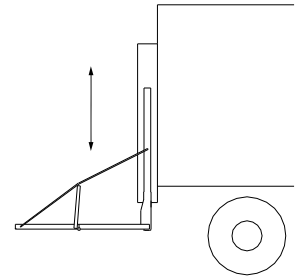
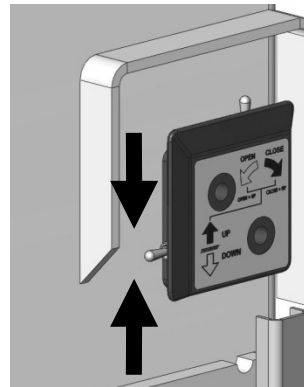

GR02036

CLOSING PLATFORM

1. With the platform open, power platform all the way up.
2. Using the “UP” toggle switch and “CLOSE” toggle switch simultaneously, power close platform.

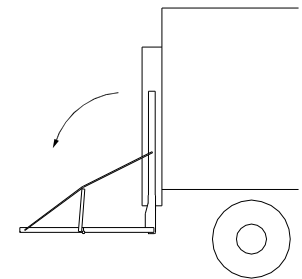
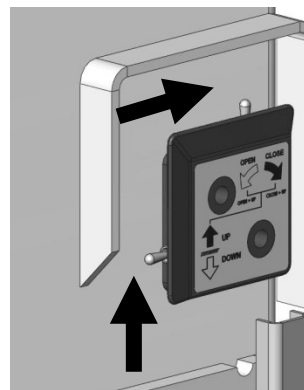

STORING PLATFORM FOR TRAVEL

1. Using the “DOWN” toggle switch, power platform down past the Travel Lock.
2. Using the “UP” toggle switch, power platform up to lift the Lock Catch.
3. Power platform up until Travel Ear clears the Travel Lock slot.
4. Use the “DOWN” toggle switch to lower Travel Ear into the Travel Lock slot.
5. Turn off power to liftgate by turning the master disconnect switch, located on pump box, to the “OFF” position.

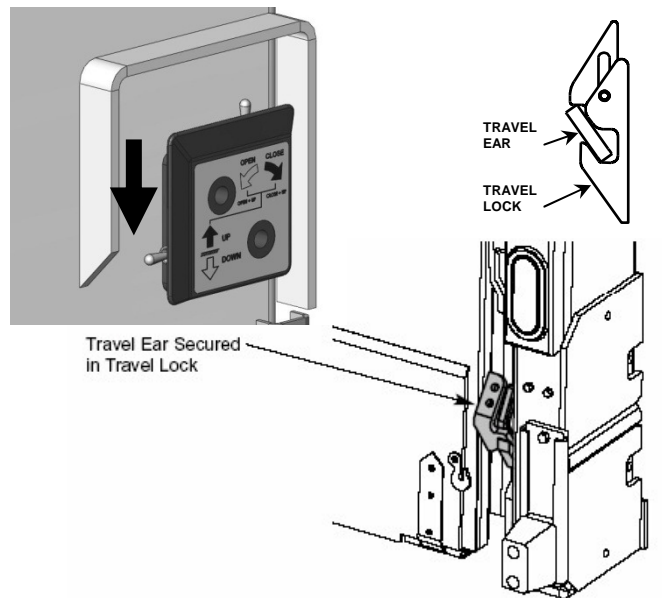

Chapter 4 Liftgate Installation

LOWERING PLATFORM FOR DOCK LOADING

1. Turn on power to Liftgate by turning the master disconnect switch, located on pump box, to the "ON" position.
2. Using the "UP" toggle switch, power platform up so that it is completely out of the travel locks.
3. Using the "DOWN" toggle switch, power platform down until the platform is level with the truck floor and hit the Dock Stops.
4. When finished Dock Loading be certain to raise platform to travel position before pulling truck away from dock.

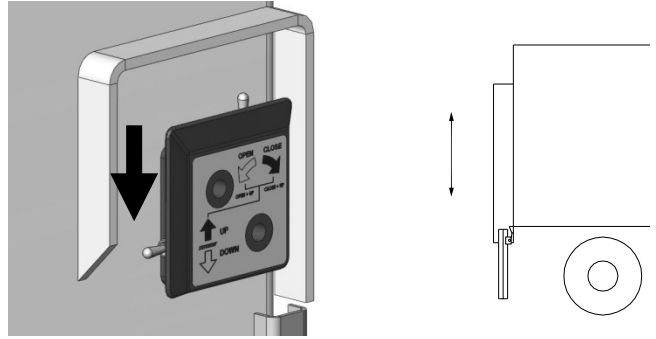

GR02038

FOLDING RAMP OPTION OPERATION INSTRUCTIONS

Unlatch ramp and unfold to loading position.

Use flip ramp chain for cart stop application.

Assure ramp is latched when in transit position.



Ensure platform and flip ramp are fully lowered when loading and unloading platform at ground level.

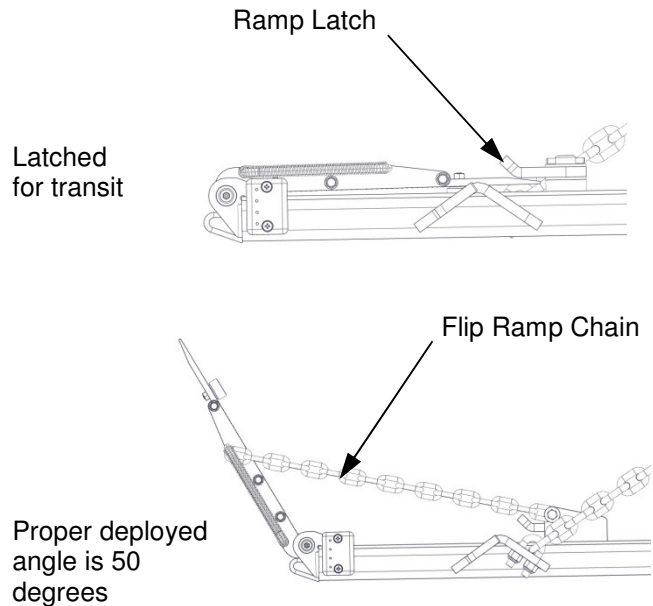

Chapter 4 Liftgate Installation

DUAL PUMP OPERATION INSTRUCTIONS

STANDARD ON WDV55 AND WDV66

The liftgate may be equipped with an optional Dual Pump Unit. The purpose of the Auxiliary Pump unit is to provide a backup in the event of a malfunction of the Primary Pump, Motor or Motor Solenoid.

The Auxiliary Pump is **NOT INTENDED FOR NORMAL OPERATION** of the liftgate. Liftgate must be repaired as soon as possible after a malfunction of the Primary Pump unit occurs.

TO OPERATE THE PRIMARY PUMP:

Move toggle switch on the pump to the "Primary Position".

Operate liftgate with controls on columns as usual.

TO OPERATE THE AUXILIARY PUMP:

Move toggle switch on the pump to the "Auxiliary Position".

Operate liftgate with controls on columns as usual.

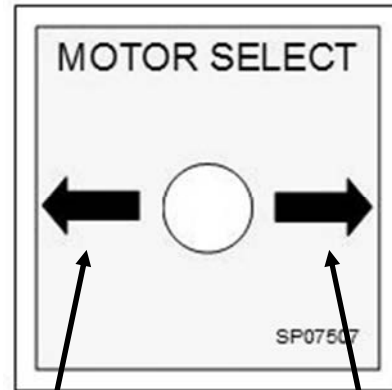

Auxiliary
Position

Primary
Position

GR02135

Double check that all hoses, wires and cables are secured under vehicle.

Paint & clean up Liftgate in areas where the Liftgate was welded to the vehicle.

It is recommended (not required) that caulking be applied between uprights, crossbeam and vehicle body in all areas not welded to reduce corrosion between the Liftgate and the vehicle.

Chapter 5- Placement of Decals



All decals must be in place and legible or all warranties are void.

Properly placed warning decals are an essential part of your safety program. Check that all safety decals are in place and are legible. Any missing decals **MUST** be replaced immediately. Replacement decals may be obtained **FREE** of charge from your distributor or by phoning, writing, or faxing Waltco Part Sales.



If your liftgate is equipped with dual controls, an additional Safety Instruction decal (80100850) is to be placed in a conspicuous place near the second set of controls.

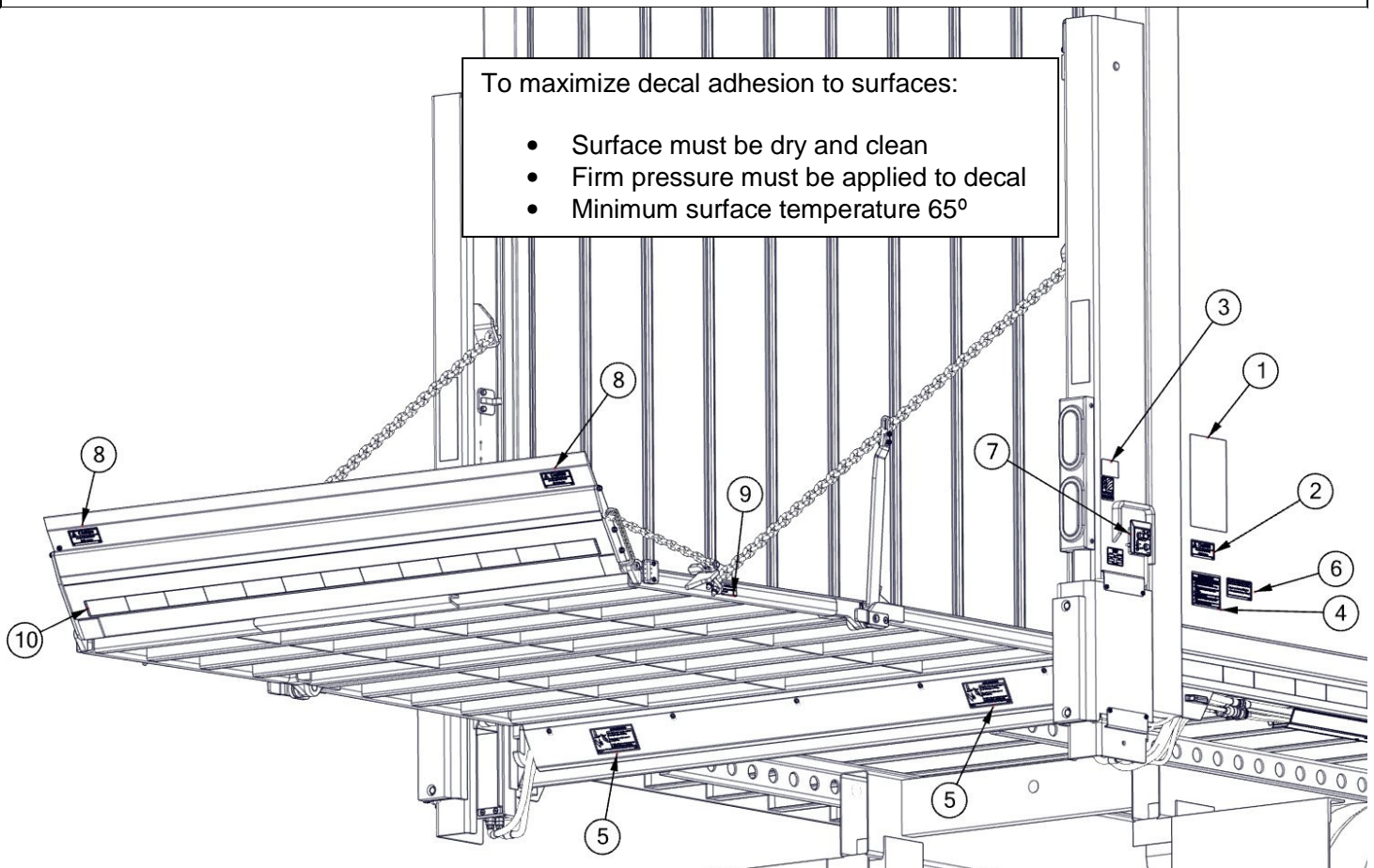

ITEM#	DESCRIPTION	WDV35	WDV45	WDV55	WDV66	WDV WITH +16 FLIP RAMP	QTY
1	OPERATING INSTRUCTIONS			80101538			1
2	WARNING, KEEP CLEAR			75089296			2
3	WARNING, MAX CAPACITY	80100586	80100261	80101308	80101309		2
4	URGENT WARNING			80100850			1
5	DEANGER, LIFTGATE CAN CRUSH			80101370			2
6	SAFETY, OPEN AND CLOSE			80101537			1
7	OPEN AND CLOSE DECAL			80101539			1
8	WARNING, KEEP CLEAR					75086296	2
9	FLIP RAMP STORAGE					80100482	1
10	CONSPICUITY TAPE FOR 96" WDV					82021067 (73.5")	1
	CONSPICUITY TAPE FOR 102" WDV					82021067 (78.5")	1

Chapter 6 Lubrication

LUBRICATION INSTRUCTIONS

The following areas ONLY should be lubricated approximately once a month, or as outlined in the lubrication scheduled for heavier usage. If not sure of duty or cycles, always lubricate more frequently.

(For all wear pads use a low viscosity lubricant such as machine oil or equivalent. For pins with grease fittings, use grease gun and appropriate high viscosity grease)

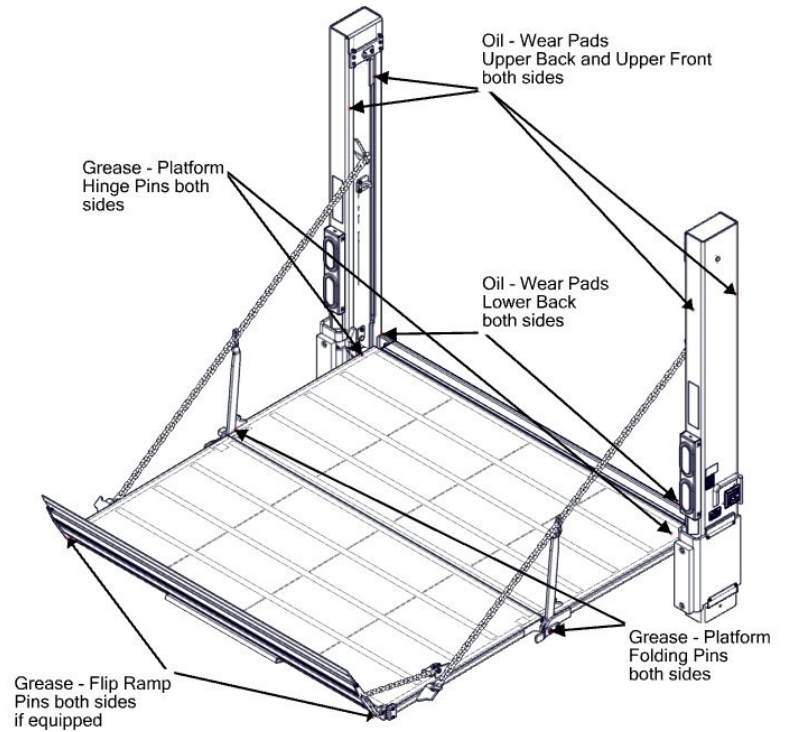

If the liftgate is a WDVBG, the additional points on the liftgate that require lubrication are the points indicated in the graphic to the right. These should be lubricated approximately once every three (3) months.

- Use a light weight machine oil to lubricate all Ramp and Guard Rail Pivot Pin areas as shown to the right.
- Grease Guard Rail Pivot Pins where zerk fittings are provided.

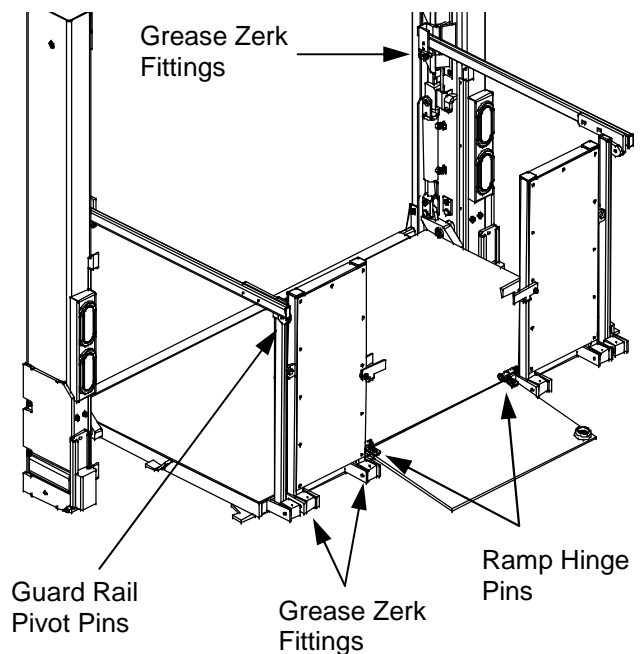

Chapter 7 Final Inspection List

IMPORTANT

All of the following items are to be checked and verified before installation is complete and liftgate is ready for service.

- 1. Does liftgate fold and unfold freely and properly?
- 2. Check that body side walls are strong enough to support WDV/WDVVG Series liftgate forces.
- 3. Check that uprights are square, parallel and travel ear engages 3/8" of passenger side cam.
- 4. Check to be certain that all hydraulic fittings are tight and leak free.
- 5. Check that platform is level with the vehicle floor.
- 6. Chain attachment bolts and linkage bolts are in place and secured with locknuts.
- 7. Check all welds to see that they are done properly.
- 8. Check all switches to see that they work properly and in the proper sequence.
- 9. Check that platform opens and closes properly and at the proper rate of speed.
- 10. Check to be sure hinge pins between the platform and the deck extension are retained with proper fasteners.
- 11. Check that Store Below Locks (if equipped) function properly.
- 12. Check that all electrical connections are done properly and that battery cable is properly secured to frame.
- 13. Check that batteries are fully charged and grounded per instructions.
- 14. Check that liftgate is properly lubricated.
- 15. Check to see that all decals are in place and legible.
- 16. Check that all nuts and bolts are tightened properly.
- 17. Check that hydraulic reservoir is full of oil.
- 18. Check that vehicle meets all state and federal standards.
- 19. Check that owner's manual is in vehicle.
- 20. Operate the liftgate throughout its entire operational cycle several times. Check that the liftgate operates freely and smoothly throughout the entire operating cycle and that there are no unusual noises while operating the liftgate.

⚠ DO NOT USE LIFTGATE IF ANY OF THE ABOVE ARE NOT CHECKED AND VERIFIED. IF YOU HAVE ANY QUESTIONS NOT COVERED IN THIS MANUAL, CONTACT YOUR NEAREST WALTCO DISTRIBUTOR, OR THE NEAREST WALTCO FACTORY.

How To Order Parts

Repairs should be made only by authorized mechanics using WALTCO Replacement parts.

When ordering repair or replacement parts, please include all the information asked for below. If this information is not available, a complete written description or sketch of the required part will help WALTCO identify and deliver the needed part to you.

THE FOLLOWING INFORMATION MUST BE INCLUDED:

1. SERIAL NUMBER - [WALTCO liftgate serial numbers can be found on the Specification Tag attached to the mount frame. (On older units the Specification Tag is located on the side or bottom of the platform.)]
2. MODEL NUMBER - [Or capacity]
3. PLATFORM SIZE

THEN INCLUDE THE FOLLOWING INFORMATION:

4. PART NUMBERS
5. DESCRIPTION
6. QUANTITY REQUIRED

MAIL, E-MAIL OR PHONE YOUR REQUEST TO:

Waltco Lift Corp
285 Northeast Avenue
Tallmadge, OH 44278
1-800-411-5685
FAX: 1-800-411-5684
E-MAIL: parts@waltco.com

ALL PARTS ARE F.O.B. FROM THE SHIPPING FACTORY

PLEASE NOTE:

To assure you of continuing and effective quality control, our warranty policy permits replacement of hydraulic cylinders, valves and motor pump units when their factory seals are intact. Parts under warranty will be exchanged promptly after careful inspection of the returned assemblies.

Dock Seal Header Kit Installation Instructions

FOR WELD ON GATES

NOTE: MAKE SURE TO RUN ALL CONNECTIONS AND INSTALL MARKER LIGHTS TO HEAD TOP BEFORE MOVING ON TO THE HEADER KIT AND PORCHLIGHT INSTALLATION

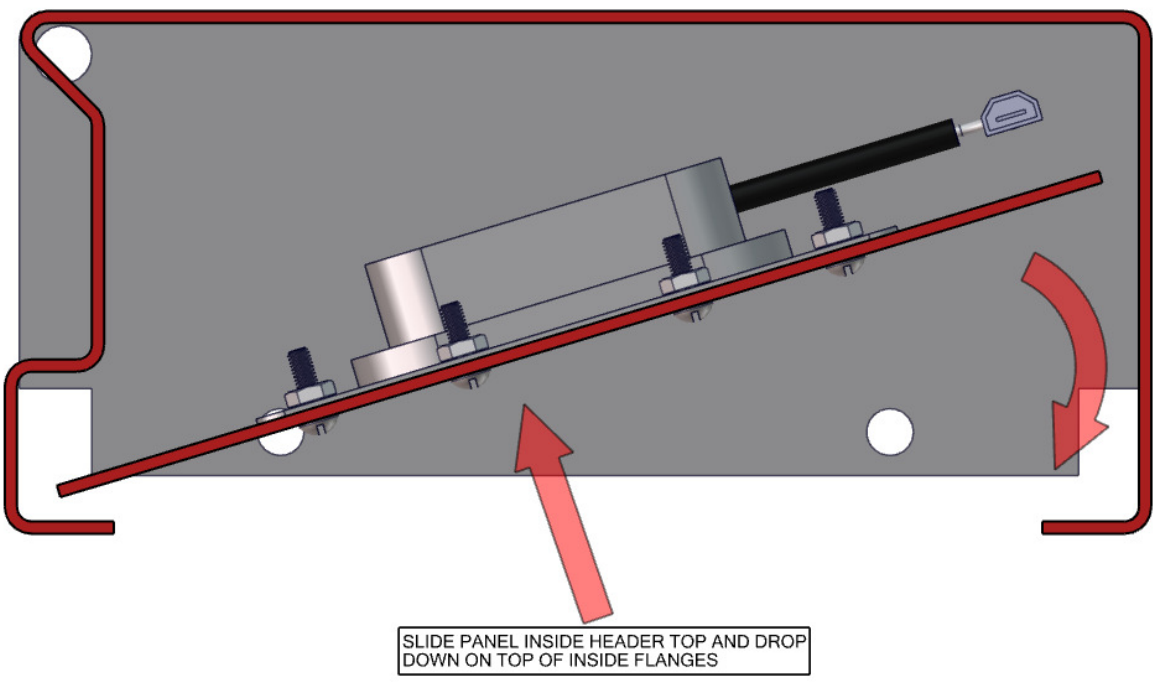
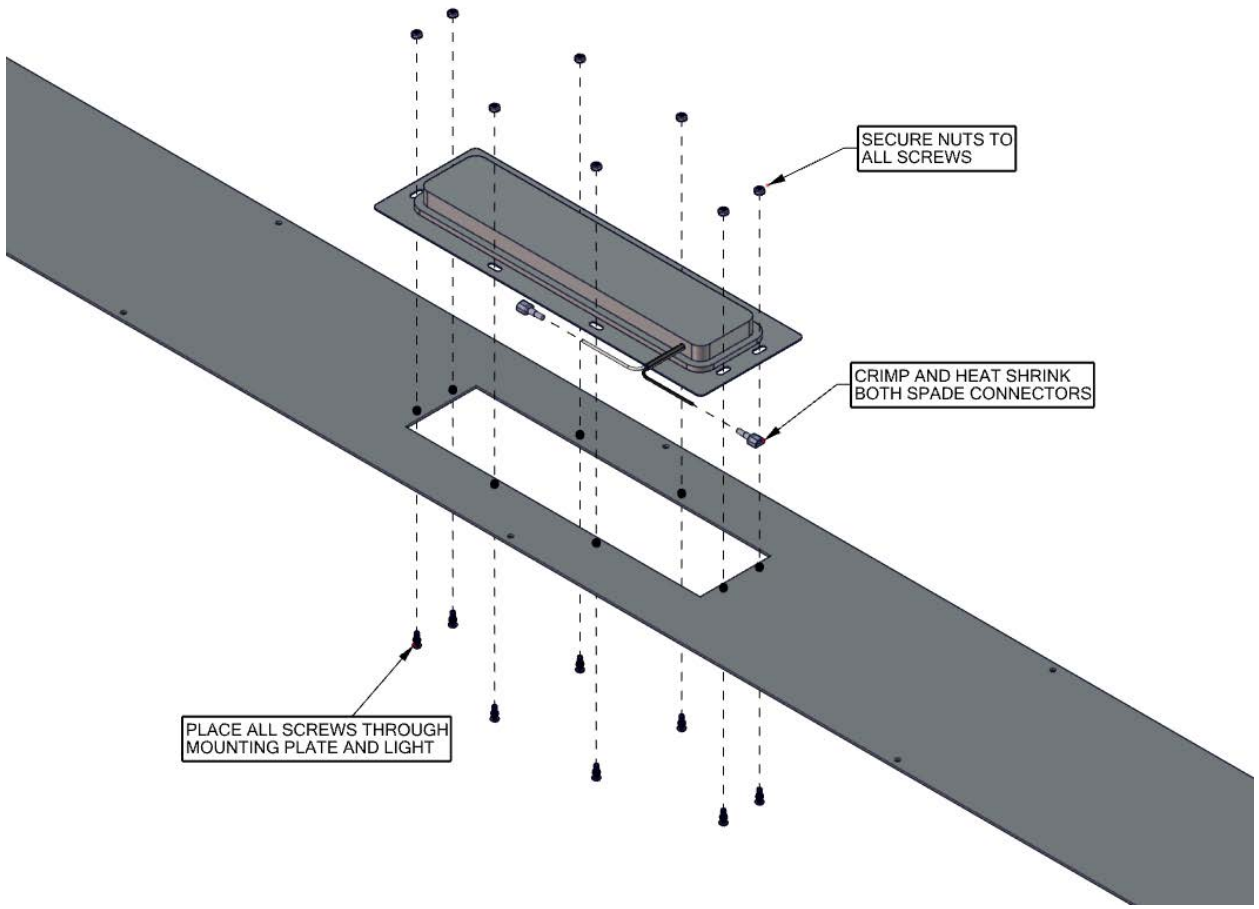

Dock Seal Header Kit Installation Instructions

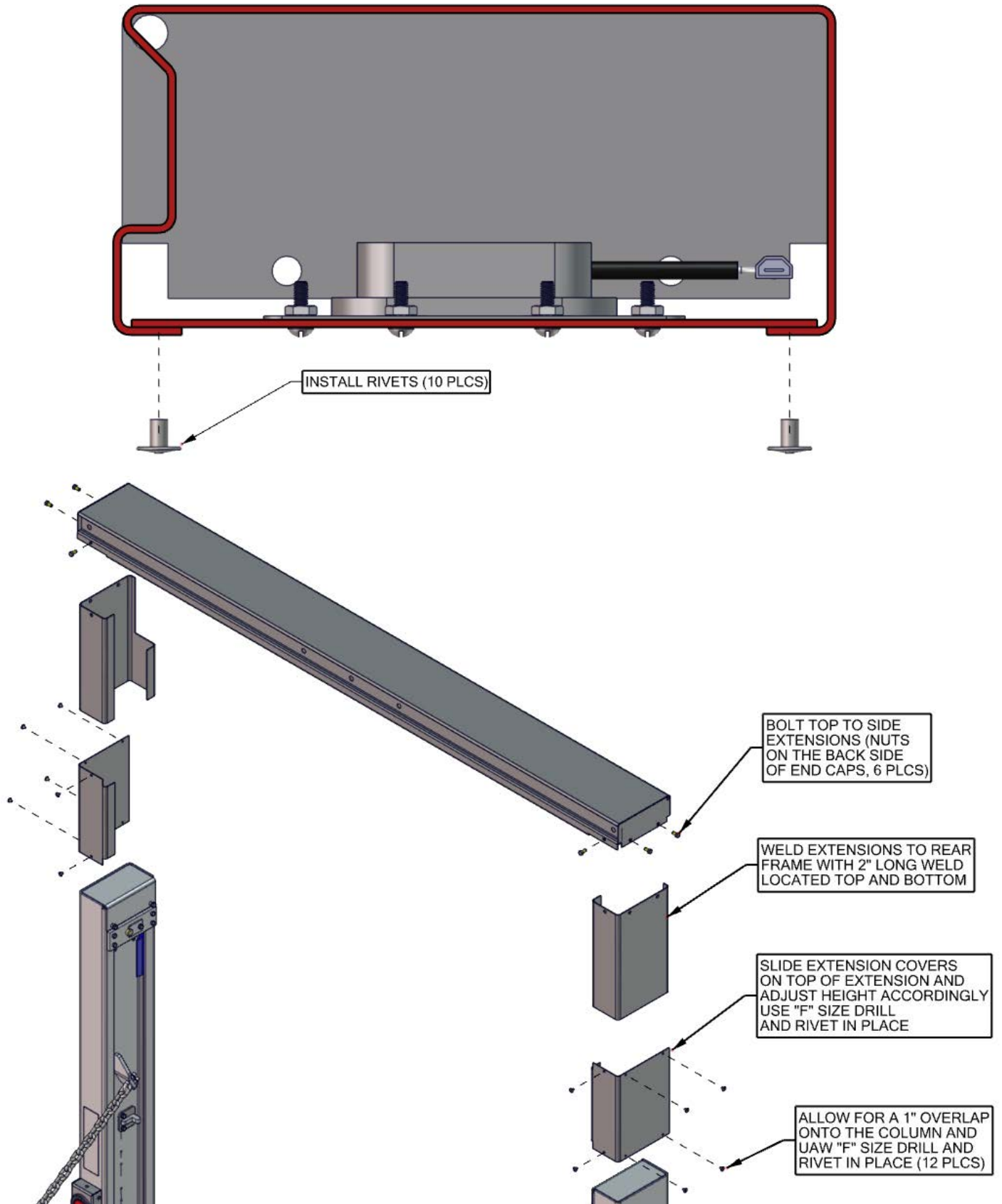

INSTALLATION DETAIL FOR TELESCOPING HEADER ASSEMBLY

Dock Seal Header Kit Installation Instructions

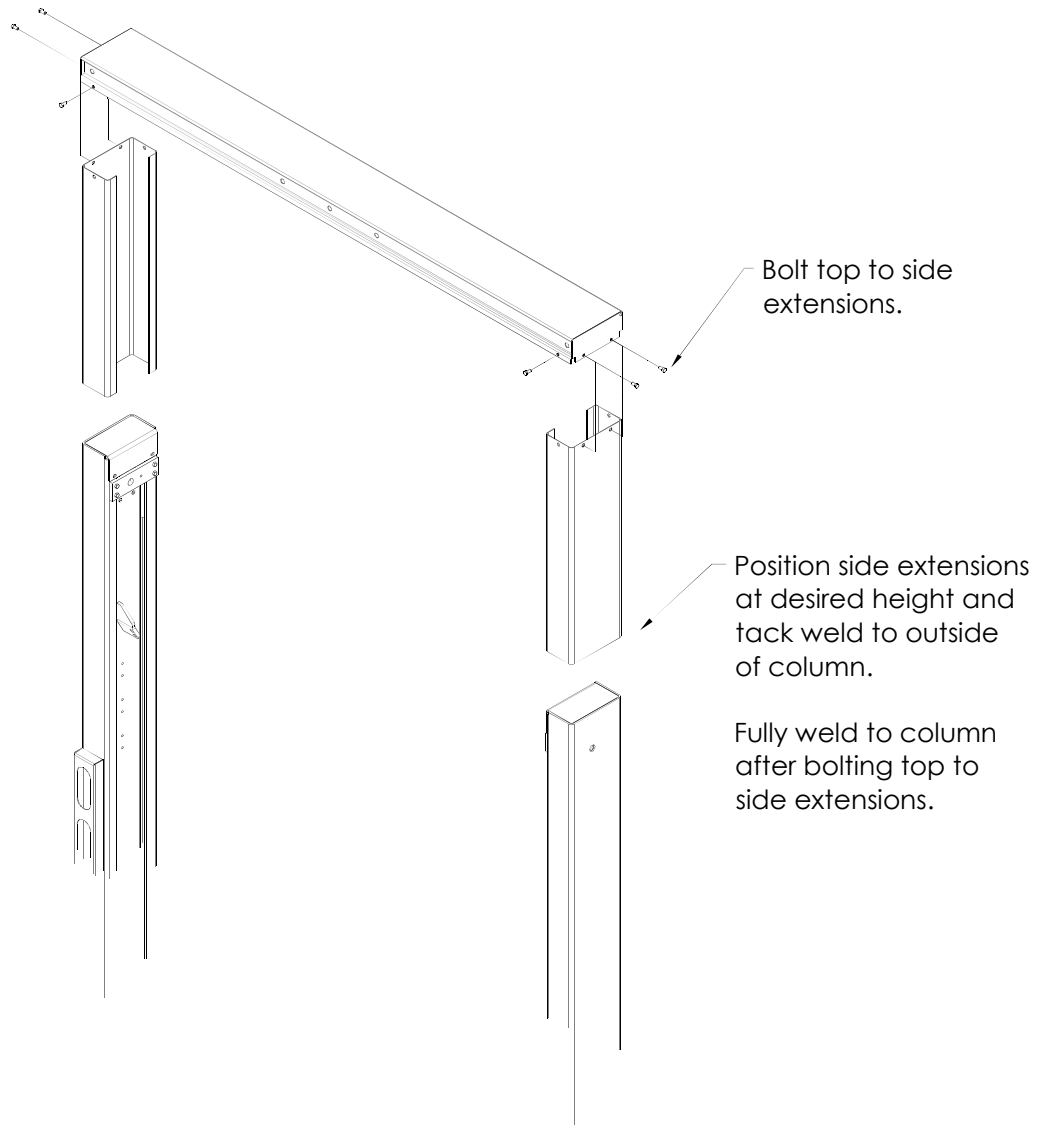

INSTALLATION DETAIL OF STANDARD NON-TELESCOPING HEADER ASSEMBLY

NOTE: STANDARD HEADER INSTALLATION IS THE SAME FOR BOLT-ON STYLE GATES

Dock Seal Header Kit Installation Instructions

FOR BOLT ON GATES

NOTE: MAKE SURE TO RUN ALL CONNECTIONS AND INSTALL MARKER LIGHTS TO HEAD TOP BEFORE MOVING ON TO THE HEADER KIT AND PORCHLIGHT INSTALLATION

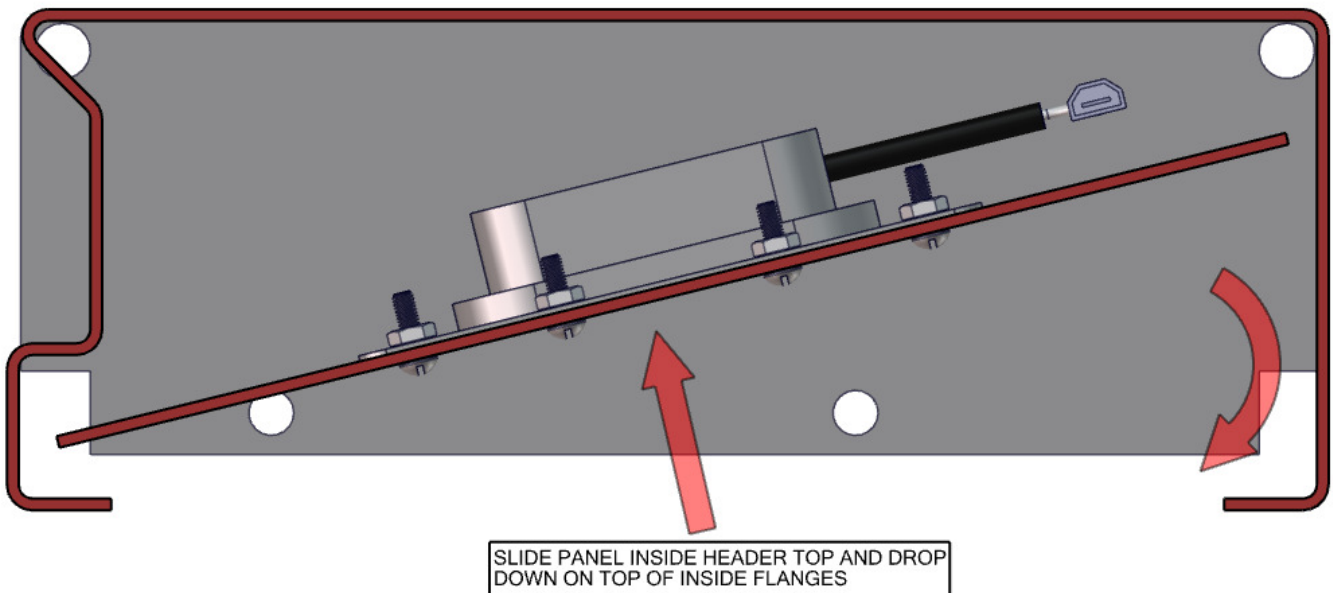
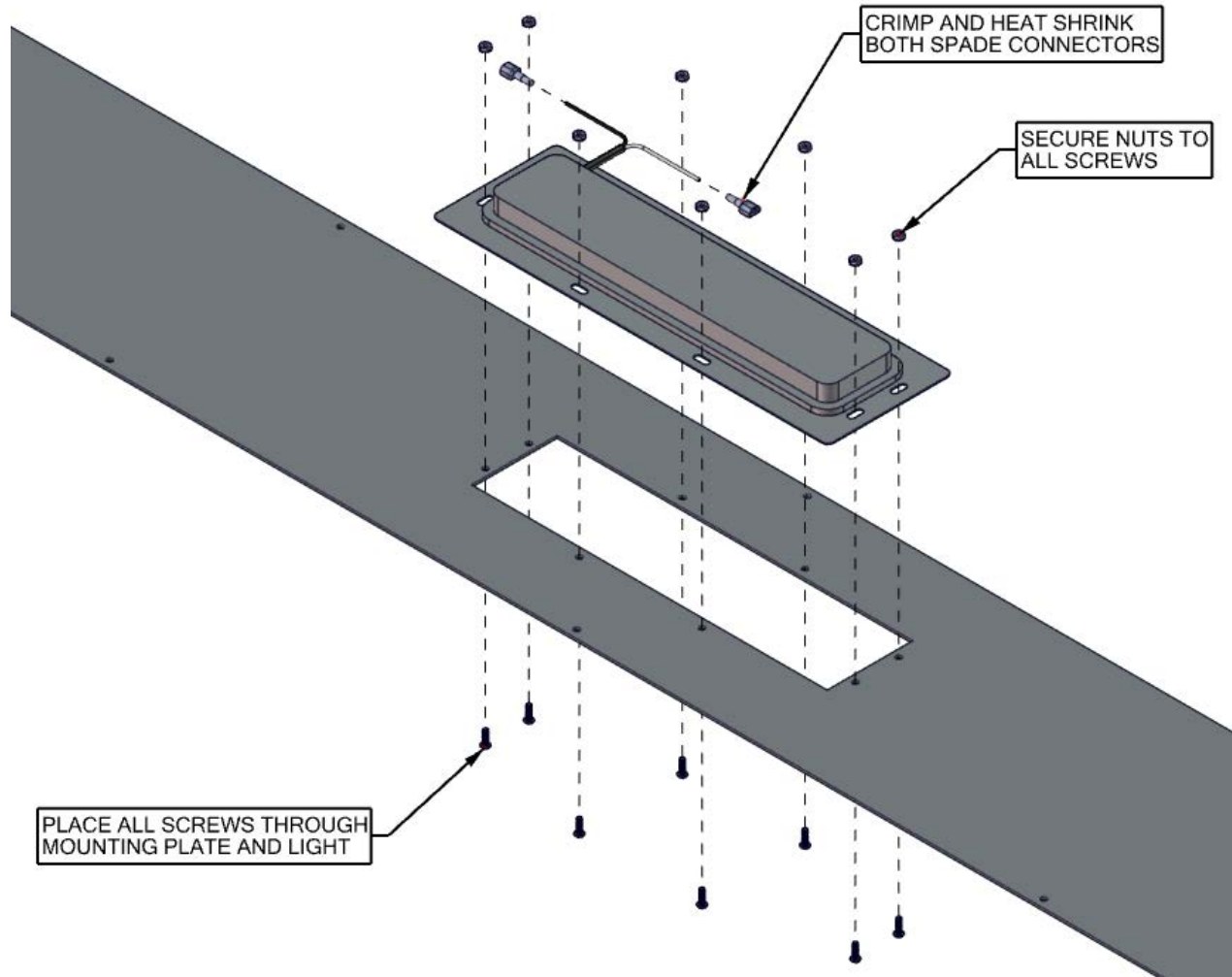

Dock Seal Header Kit Installation Instructions

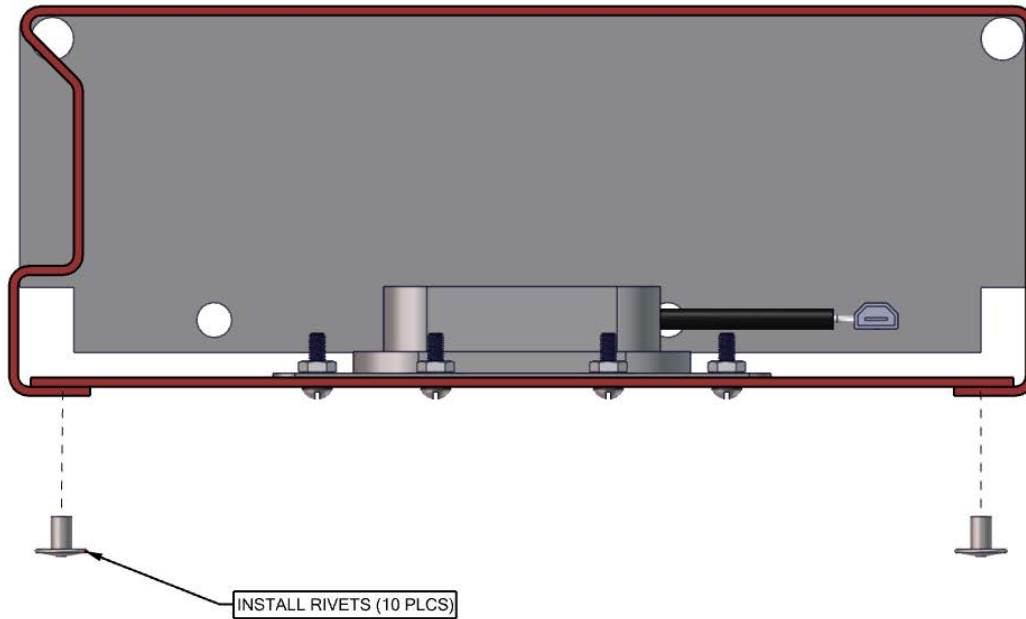

LOCATION OF EXTENSION BRACKET FROM TOP OF HEADER

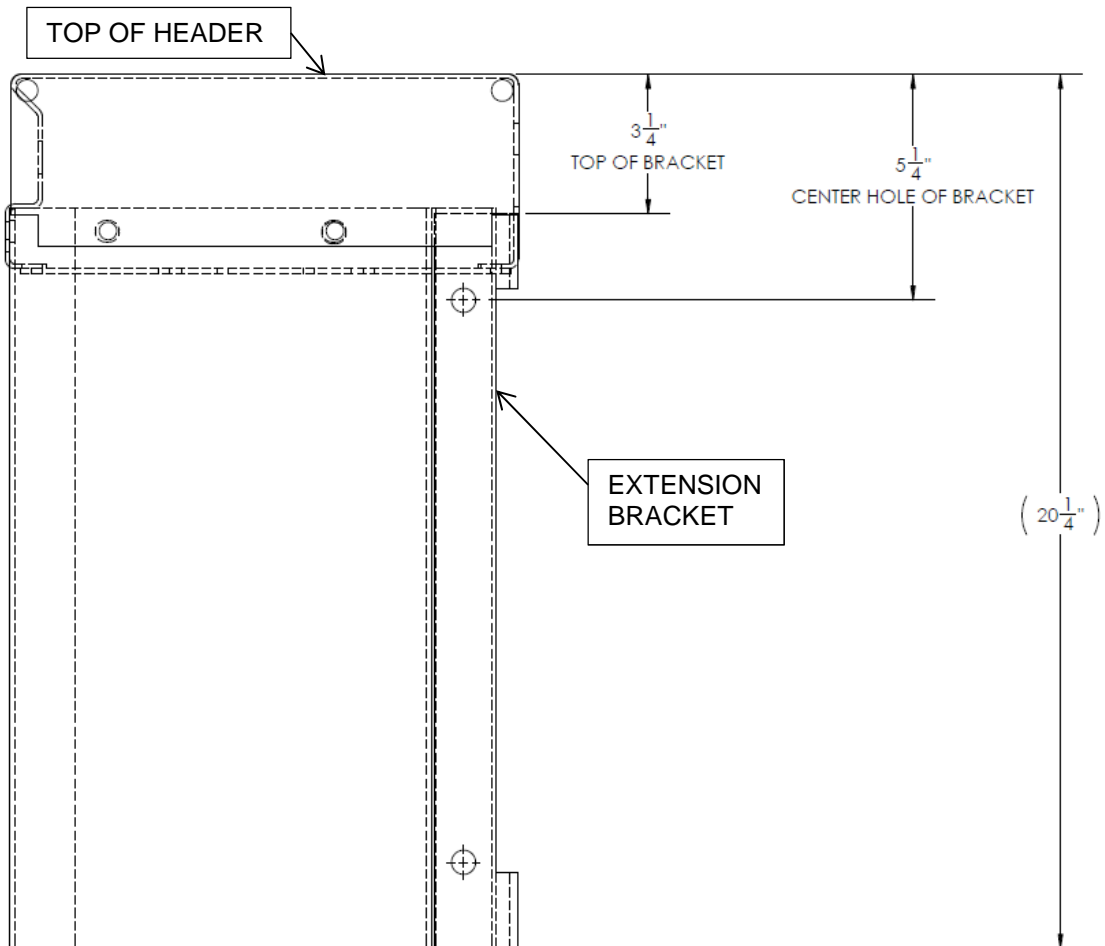

Dock Seal Header Kit Installation Instructions

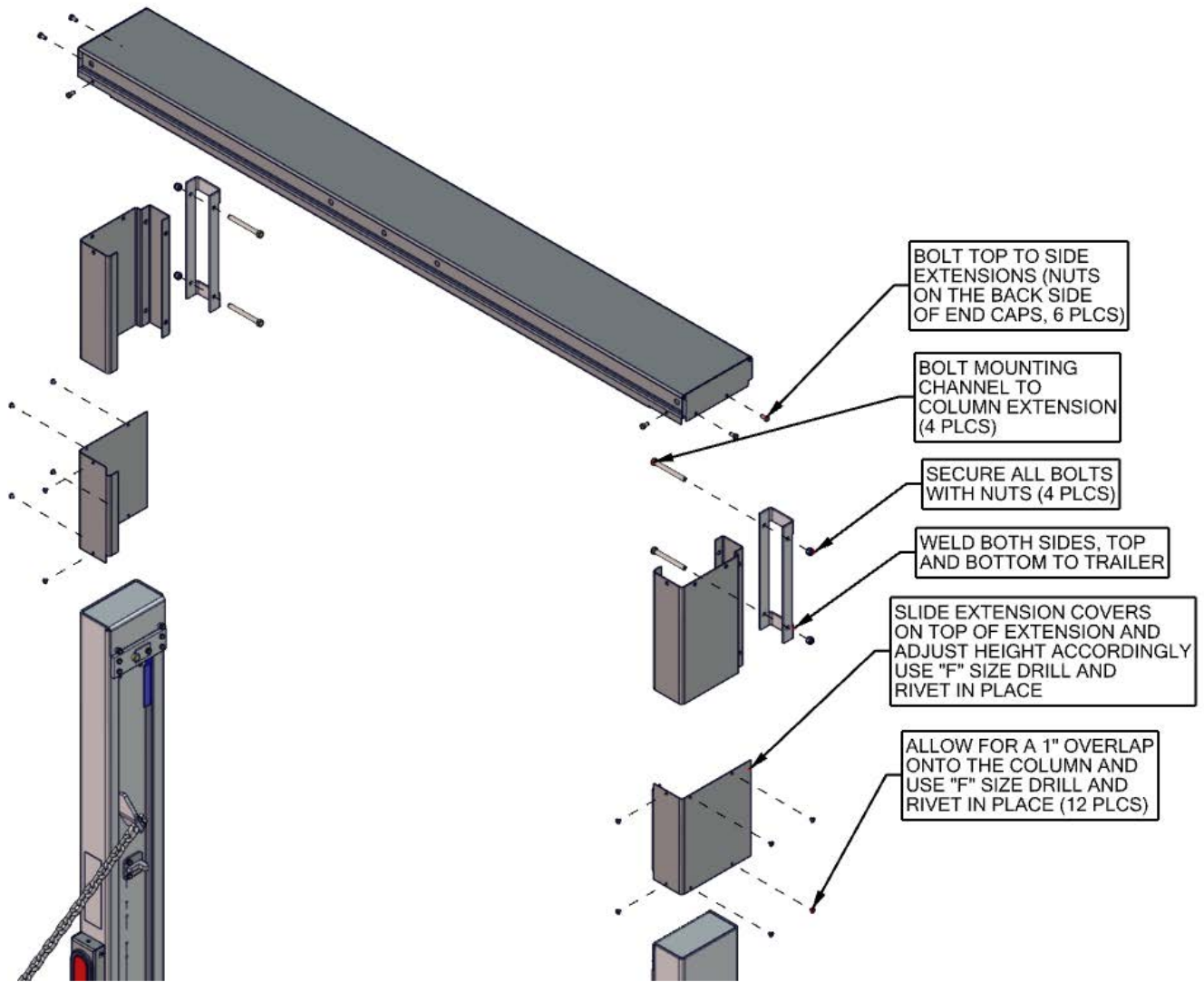

STORE AT BED LEVEL INSTALLATION INSTRUCTIONS

1. With the platform closed, lower platform all the way down until it contacts the stops on the threshold.
2. Determine if the height of the platform is acceptable. There are stop blocks included in the kit that can be used to raise the height of the platform 1-1/4" so that the mating surfaces of the platform is closer to the bed height of the trailer.
3. If the higher position is desired then open the platform and weld the blocks, part #7 shown in the diagram below and the picture on the next page, onto the down stops on the threshold.

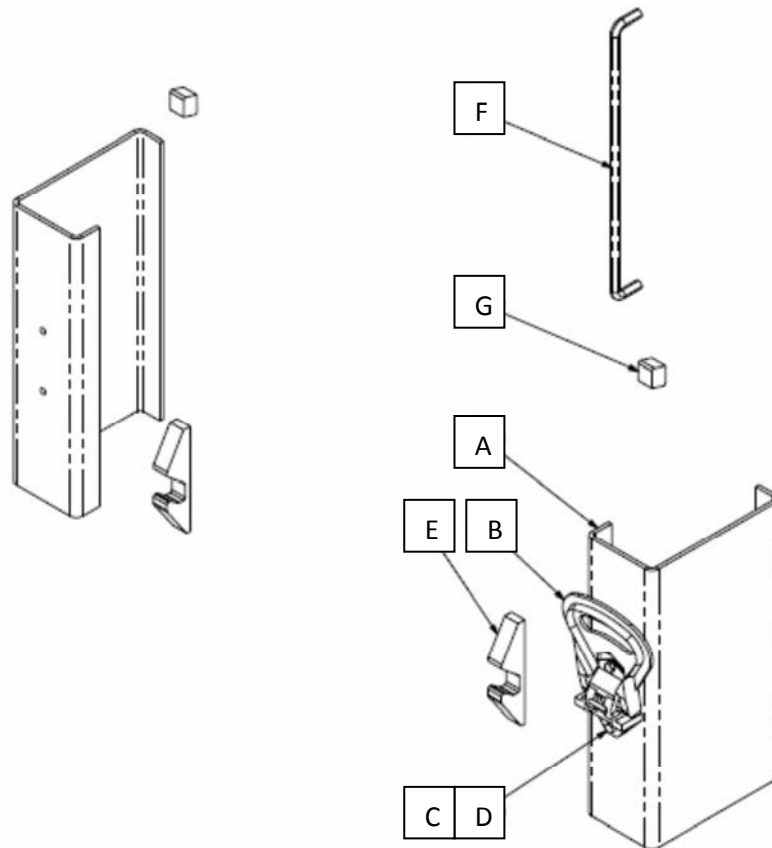

4. Grind enough paint off the bottom of the column for proper welding.
5. Clamp the column extensions onto the bottom of the columns flushing up the outer surfaces of the column and column extensions. Leave a gap between the two pieces to make sure proper weld penetration is achieved.
6. Weld the column extensions onto the bottom of the columns. Grind the welds flush if desired.
7. With the platform in the closed position, lower the platform until it contacts the down stops.

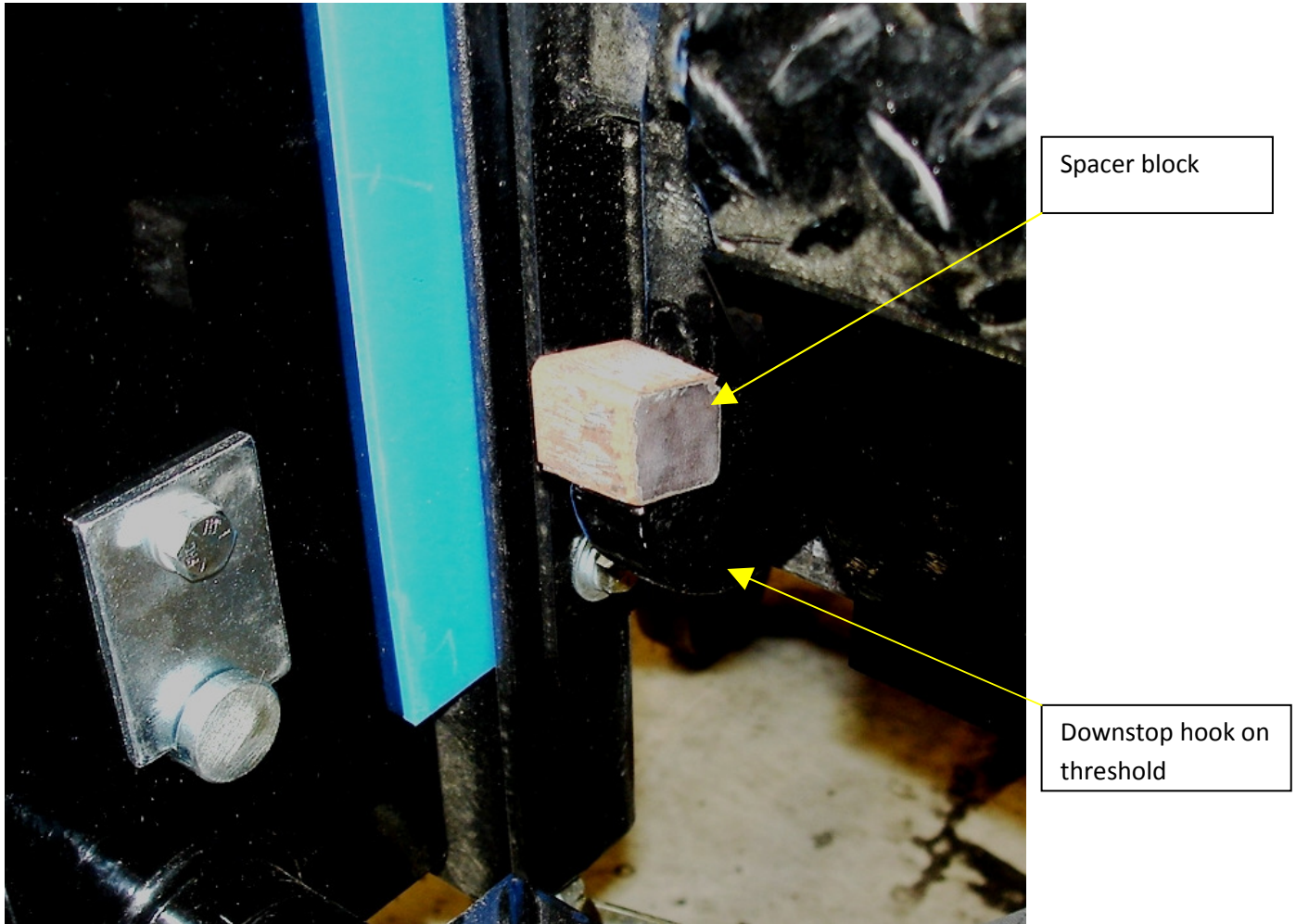

8. Position the travel latches, part #5, onto the inside surface of the column extension using the travel ears on the deck extension as a guide. Tack the travel latches in position.
9. Raise and lower the platform to ensure proper motion in and out of the travel latches.
10. If satisfied with the latching motion of the platform weld the travel latches onto the column extensions with a $\frac{1}{4}$ " fillet weld on both sides of the travel latch.
11. Bolt the folding step onto the curbside column using the hardware supplied.
12. Locate the handle, part #6, onto the curbside column at a convenient height.
13. Touch up the paint on the columns at the weld sites.

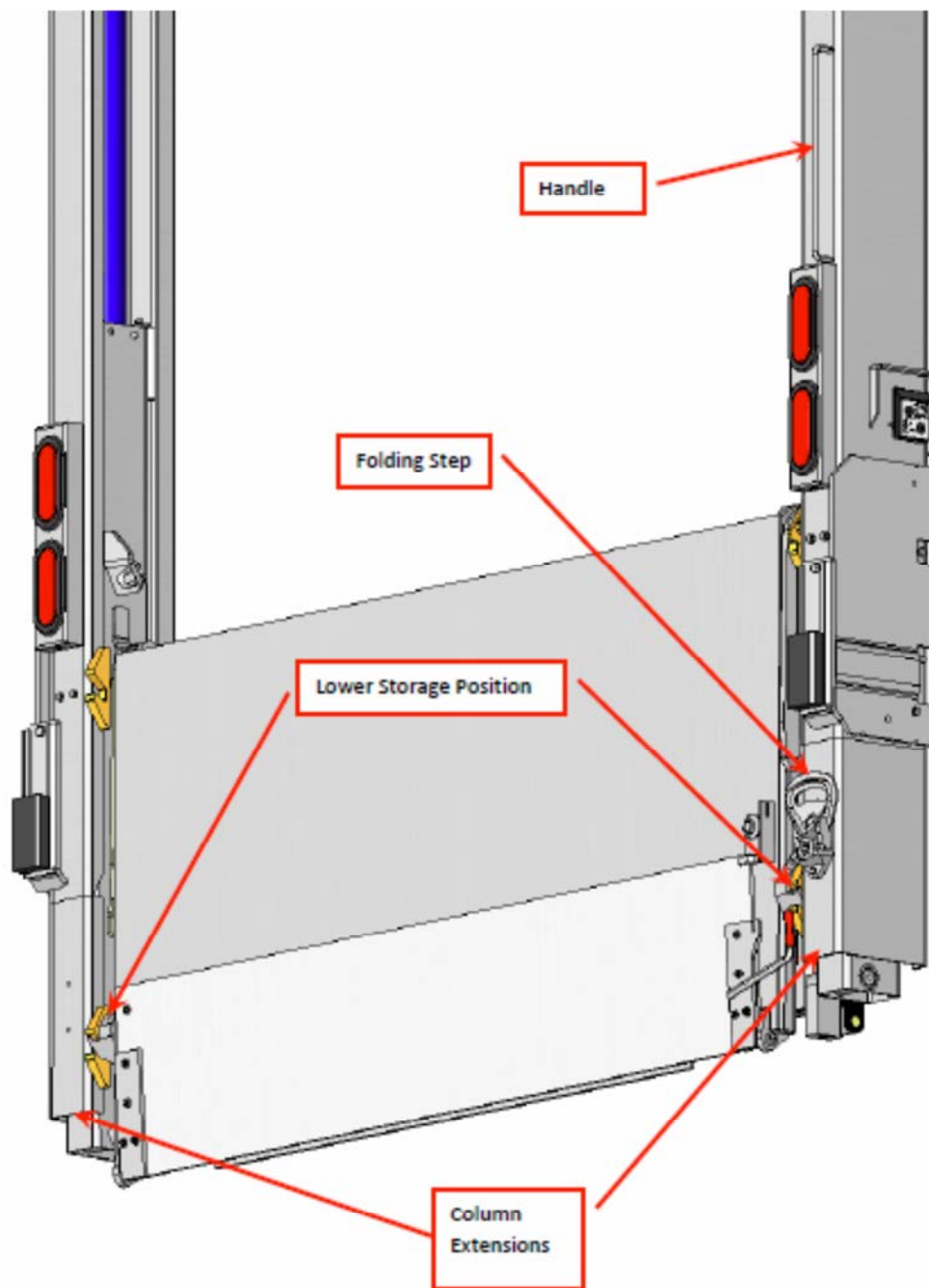

WDV Hand Held Remote Installation

DRILL SOCKET HOLES

Using dimension shown, drill mounting holes in desired location for socket.

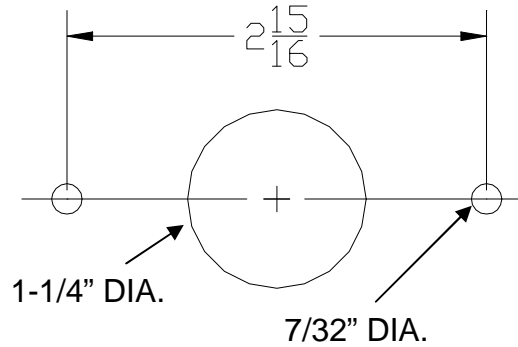

GR00036

INSTALL SOCKET

Assemble socket as shown.

Install wires according to colors:

W = White (Raise)

B or BK = Black (Lower)

G = Green (Power)

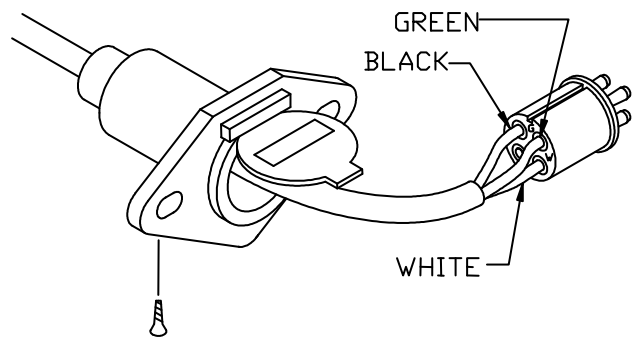

GR02241

CONNECT WIRES TO PUMP UNIT

Add 7/8" hole in box to route control cord into pump enclosure.

Use hole grommet to prevent damage to cord.

Use W/D shown below to configure control chord in pumpbox.

Apply 80101559A schematic decal over existing decal on underside of pumpbox cover.

WDV Hand Held Remote Installation

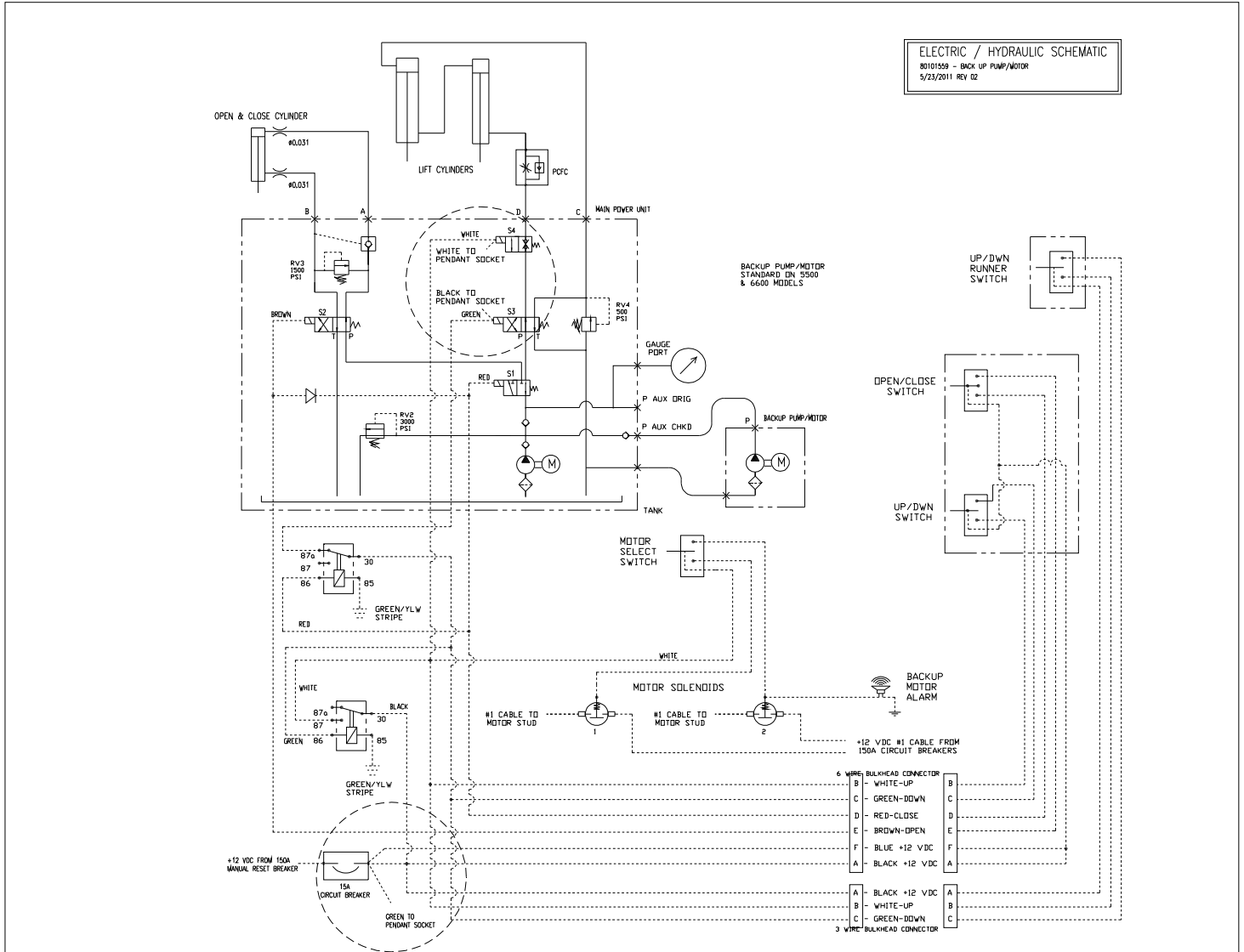

IMPORTANT

WARNING

Improper operation and maintenance of this liftgate could result in severe personal injury or death.

Read and understand the contents of liftgate Owner's manual and all warning and operation decals before operating and/or performing maintenance on this liftgate.

For SAFETY information on this liftgate see Chapter 1 of Owner's manual